

IMPROVISED LAND MINES

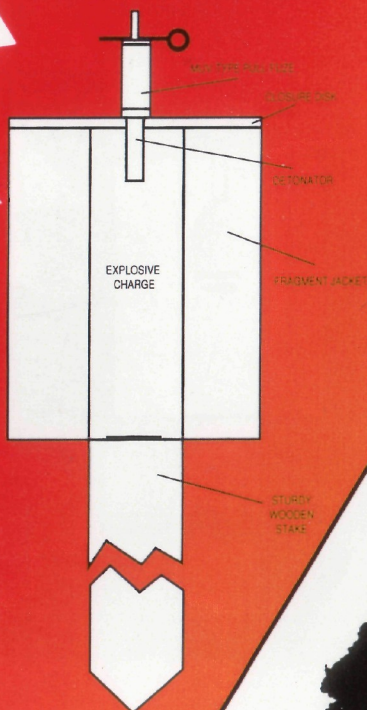

**Their
Employment
and Destructive
Capabilities**

David Harber

CONTENTS

| | |
|---------------------------------|----|
| Introduction | 1 |
| Fuzing Systems | 3 |
| MUV-Type Pull Fuze | 5 |
| Buck Igniter | 8 |
| High-Explosive Filler | 10 |
| Friction Fuze | 12 |
| Mine Construction Materials | 14 |
| TMB-2-Type Antitank Mine | 22 |
| Guerrilla Employment of Mines | 23 |
| Minelaying Tricks | 24 |
| Antipersonnel Mines | 27 |
| Soup-Can AP Mine | 29 |
| PMD Bottle Mine | 34 |
| Fragmentation Mines | 37 |
| Claymore Mines | 43 |
| Vietcong Directional Mines | 50 |
| Coffee-Can Claymore | 53 |
| Antitank Mines | 55 |
| Plate-Charge Antitank Mine | 57 |
| Number 75 Hawkins Grenade Mine | 58 |
| Improvised Artillery-Shell Mine | 59 |
| Shaped-Charge Principles | 61 |
| Vertical-Penetration Mines | 65 |
| Horizontal-Penetration Mines | 69 |
| Flying Mine | 74 |
| Plastic Bonded Explosives | 78 |

INTRODUCTION

Although land mines were used on a few occasions during the U.S. Civil War, mine warfare as we know it today came into its own during World War I. It was used as a way of dealing with the then-new menace of tank warfare. The Germans used command-detonated artillery shells quite effectively for this purpose, while the Allies improvised artillery-shell mines that detonated under the weight of enemy tanks.

Explosive mines are divided into two basic types: anti-tank (AT) and antipersonnel (AP). The AT or, more properly, antivehicular mines are larger, usually containing from 12 to 30 pounds of high explosive. Their fuzes require a greater amount of pressure to activate, in the neighborhood of 300 to 400 pounds. Mines with a lower explosive content (5 pounds or so) are sufficient for trucks and autos, if stopping them is the only requirement.

AT mines are further subdivided into blast and killer types. Blast mines serve only to disable a tank by blowing off the driving tread and giving the crew mild heart attacks. The tank still must be finished off with satchel charges or flame weapons. Killer mines use specially designed explosive charges to penetrate the tank's hull, either through the comparatively thin belly armor or through the side armor near the drive wheels. (These will be covered in more detail in the AT section, beginning on page 55.)

AP mines use the blast or fragmentation effect to cause death or injury to unmounted personnel. Most modern blast-type AP mines contain from 1 to 4 ounces of high explosive. That is plenty to cause a disabling wound, and it is often better to maim an enemy soldier than to kill him. Dead bodies may be left where they fall, if necessary, but a wounded comrade must be cared for. Not only will he be a strain on the medical logistics of a military force, but a blow to morale as well. At the risk of sounding callous, the sight

IMPROVISED LAND MINES

CIVIL WAR LANDMINE CONVERTED 24-POUND ARTILLERY SHELL

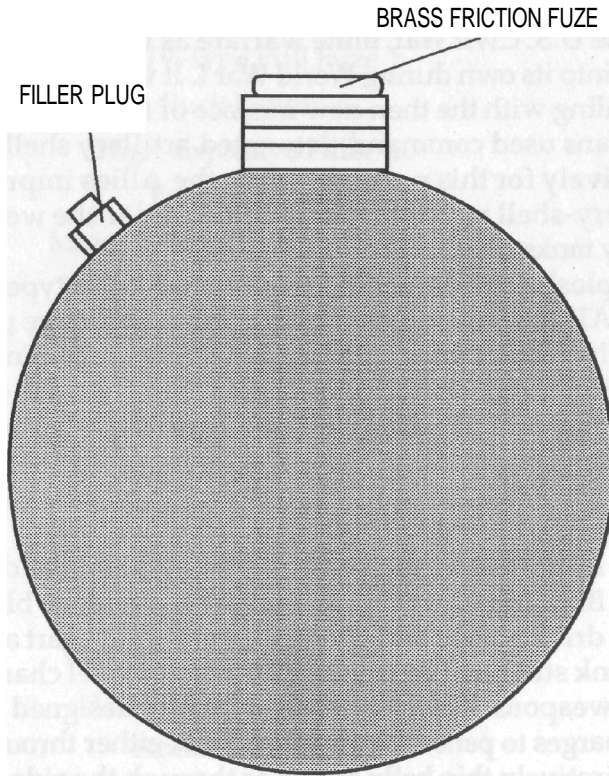

and sound of a man with his foot blown off is much more damaging to the morale of a unit than the sight of a dead one. Corpses don't scream.

Fragmentation or "frag" mines employ either a thick metal casing or a layer of shrapnel, such as ball bearings (as in the U.S. claymore mine). The amount of explosive used in these types depends on the sophistication of the design and the range required. Sizes vary from the tiny DH-3 used by urban Vietcong units to the massive Soviet MON-200, which weighs more than 25 kilograms.

FUZING SYSTEMS

The heart of any explosive device is the fuzing system or, simply, fuze. Four basic types are used: mechanical, chemical, electrical, and friction. Each has its advantages and disadvantages.

Mechanical Fuzes

This type uses a firing pin propelled by a spring to strike a percussion primer cap and detonate the mine. Though the specific forms this apparatus takes vary widely, they all boil down to the same thing: a spring and a firing pin. This fuze may be left in place for long periods of time—even years—if protected from corrosion, but it is generally more difficult (a relative term) to construct. The MUV is a classic example.

Chemical Fuzes

This fuze mixes two chemicals that produce a flash of intense heat to ignite the detonator. The most common combination of chemicals involves a chlorate (sodium or potassium) and concentrated sulfuric acid. In some cases, match heads are substituted for the chlorate powder. If the chemicals are available, this is a simple, reliable fuze that has much to recommend it. Its only drawbacks are that the chlorate mixture is somewhat sensitive to moisture (especially if sodium chlorate is used), friction, and sparks. To eliminate this problem, seal the chlorate in a glass vial, just as you do the sulfuric acid. To activate the fuze, arrange for both vials to be broken at the same time.

Electrical Fuzes

The electrical fuze has a simple switch to route power from a battery to an electric detonator. Its main drawback is

the battery, which has a definite shelf life and may become inert after an extended period of time or when subjected to extreme heat or cold. The entry of moisture into the fuze may also cause a short circuit and thus premature detonation or misfire.

Friction Fuzes

The friction fuze uses the principle of the common friction match to ignite the detonator. A pressure piece containing the head of a wooden match is pushed down a tube lined with a red phosphorus-based friction material. Friction between the two surfaces causes the match head to light, ignite the black powder in the tube, and fire the detonator. The friction fuze is sensitive to moisture and should be well-sealed to prevent its absorption. Properly made, this fuze is simple and reliable.

Choosing a fuze type depends on preference, availability of materials, and performance requirements. Certain types of fuzes work better in certain types of mines.

MUV-TYPE PULL FUZE

Probably the most basic pull fuze is the MUV or "cocked striker" type. The MUV has been used by the Soviets since the middle of World War II, and it seems that every country in the world has its own variation. The design is simple and straightforward. A spring-loaded firing pin or striker is restrained by a safety pin. When the safety pin is withdrawn, the spring propels the striker down the tube to impact the primer, which, in turn, causes the blasting cap to detonate.

The materials used in its construction are widely available: nails, springs, tubes or pipe parts, etc. MUVs have been made out of cartridge cases, plastic, and even wood (the Soviets made a version entirely of wood, except for the spring and striker point). The example shown was built from 1/2-inch copper pipe parts.

If the safety pin is replaced with a "shear" pin made of copper or mild steel, this type of fuze may also be employed as a pressure fuze in AT mines. Paper clips make good shear pins, as do common finishing nails that have been "detempered" by heating them to red hot and allowing them to cool slowly. When pressure is directed straight down on the striker shaft, it shears the pin, allowing the fuze to function. The amount of pressure required depends on the pin material. The pressure piece that bears against the end of the striker shaft should be made of a hard material such as ceramic or metal. Wood is unsatisfactory because the end of the striker shaft may become imbedded in it, possibly causing a misfire.

No construction details are necessary; simply refer to the drawing.

IMPROVISED LAND MINES

MUV-TYPE PULL FUZE

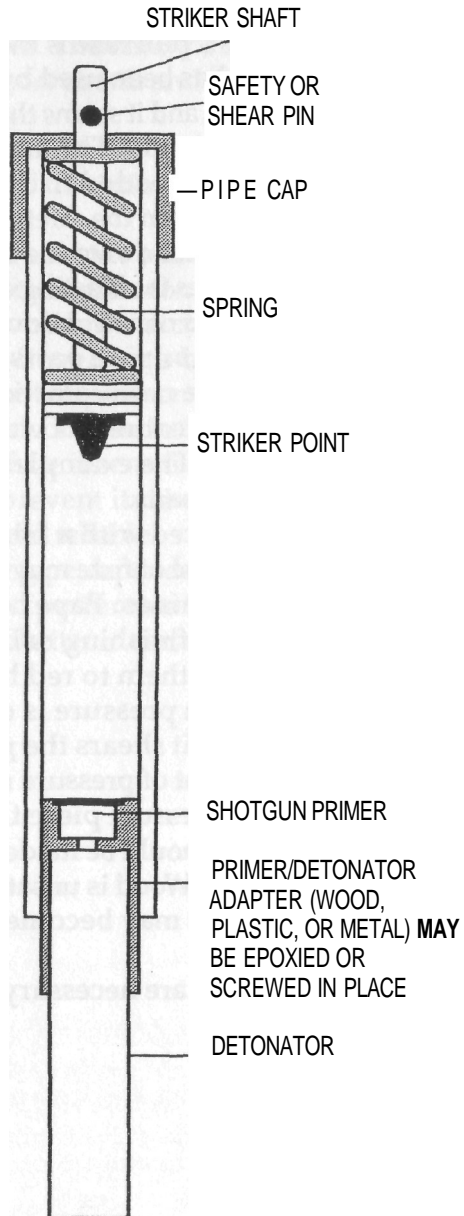

THEIR EMPLOYMENT AND DESTRUCTIVE CAPABILITIES

ALTERNATE-TYPE COCKED FIRING PIN FUZE

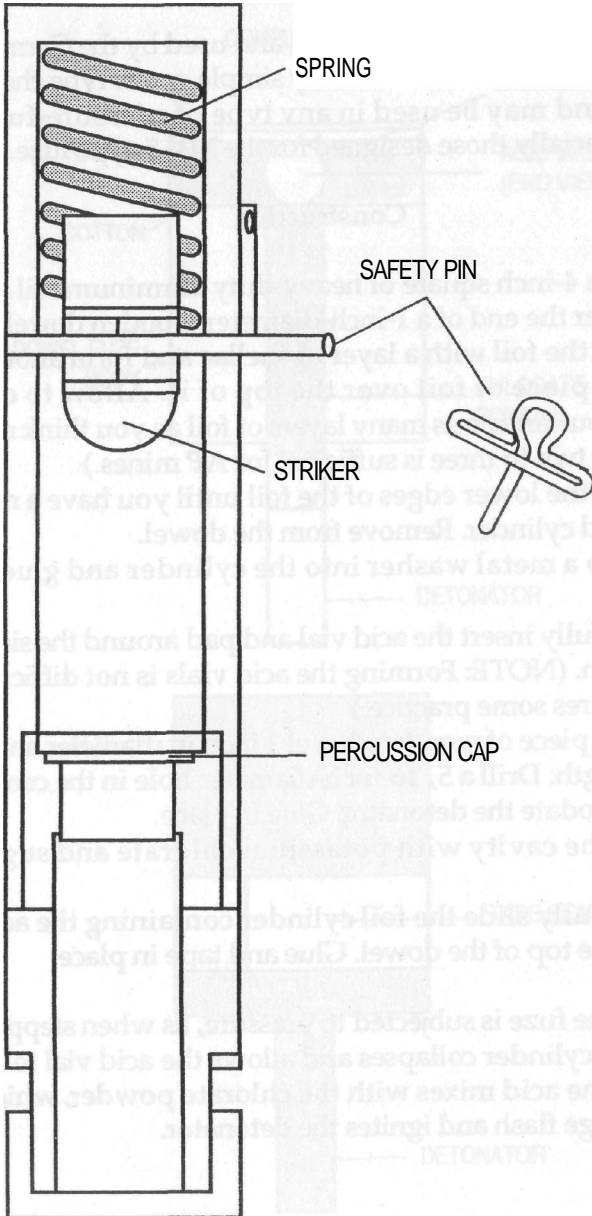

BUCK IGNITER

The buck igniter was designed and used by the Germans in World War II. It is an extremely simple crush-type chemical fuze and may be used in any type of pressure-fuzed mine, especially those designed for the MV-5-type fuze.

Construction

1. Cut a 4-inch square of heavy-duty aluminum foil and form it over the end of a 1-inch-diameter wooden dowel.

2. Coat the foil with a layer of shellac and form another identical piece of foil over the top of it. Allow to dry. (NOTE: You can use as many layers of foil as you think necessary, but two to three is sufficient for AP mines.)

3. Trim the lower edges of the foil until you have a neat can-shaped cylinder. Remove from the dowel.

4. Drop a metal washer into the cylinder and glue in place.

5. Carefully insert the acid vial and pad around the sides with cotton. (NOTE: Forming the acid vials is not difficult, but it requires some practice.)

6. Cut a piece of wooden dowel 1 inch in diameter and 1 inch in length. Drill a 5/16-inch-diameter hole in the center to accommodate the detonator. Glue in place.

7. Fill the cavity with potassium chlorate and sugar granules.

8. Carefully slide the foil cylinder containing the acid vial over the top of the dowel. Glue and tape in place.

When the fuze is subjected to pressure, as when stepped on, the foil cylinder collapses and allows the acid vial to be (rushed. The acid mixes with the chlorate powder, which causes a large flash and ignites the detonator.

THEIR EMPLOYMENT AND DESTRUCTIVE CAPABILITIES

BUCK IGNITOR

COMPLETED FUZE

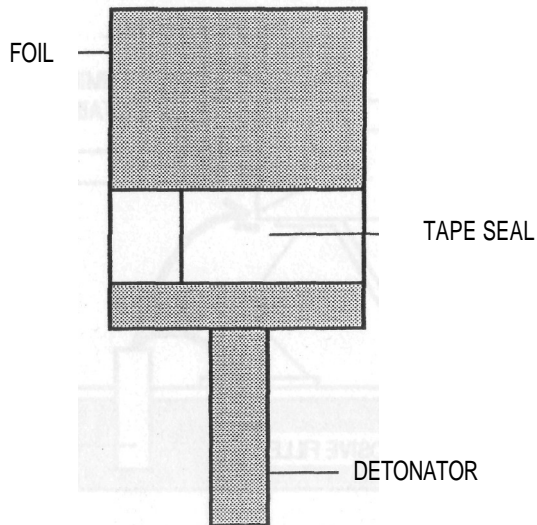
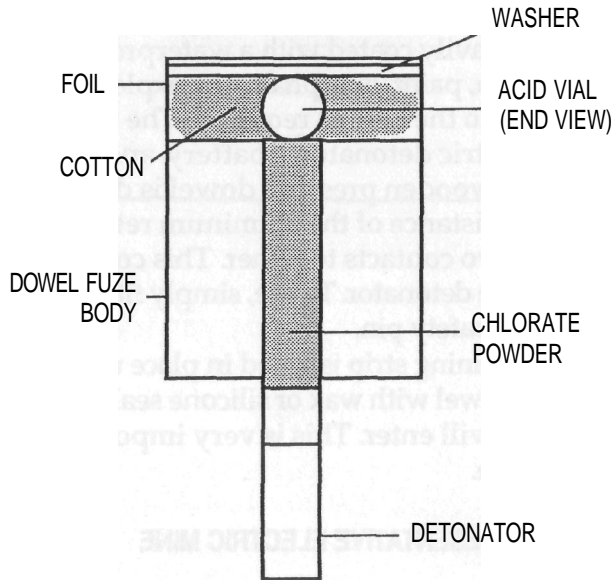

HIGH-EXPLOSIVE FILLER

The pictured device is a simple square box made of 1/2-inch pine boards and 1/4-inch plywood for the top and bottom. The box is heavily coated with a waterproofing material such as varnish, paint, or asphalt. The explosive may be cast or pressed into the case as required. The fuze system comprises an electric detonator, a battery, and two metal strips. When the wooden pressure dowel is depressed, it overcomes the resistance of the aluminum retaining strip and presses the two contacts together. This completes the circuit and fires the detonator. To use, simply fit it into place and withdraw the safety pin.

NOTE: The retaining strip is glued in place using epoxy. Seal around the dowel with wax or silicone sealer to ensure that no moisture will enter. This is very important for an electric-fuzed mine.

REPRESENTATIVE ELECTRIC MINE

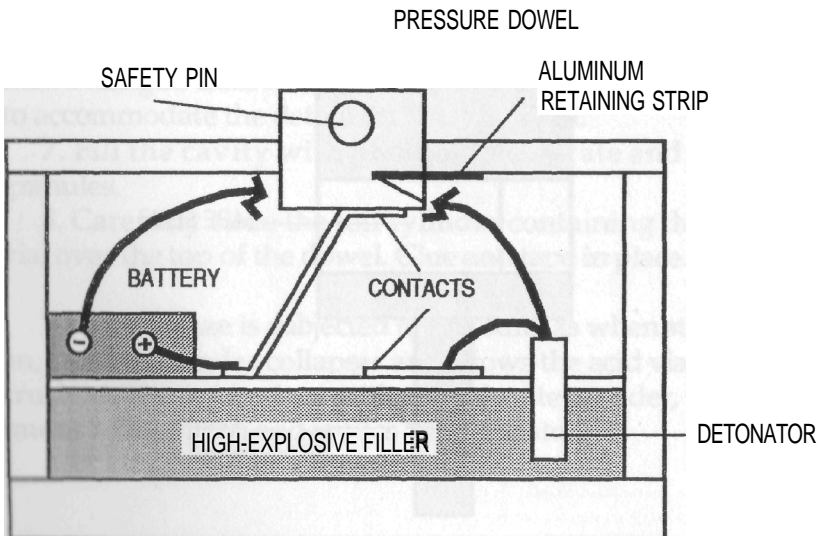

THEIR EMPLOYMENT AND DESTRUCTIVE CAPABILITIES

ELECTRIC MINE CIRCUIT DRAWING

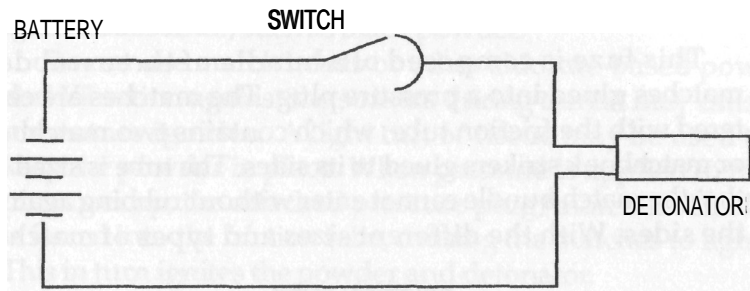

FRICION FUZE

This fuze is composed of a bundle of three wooden matches glued into a pressure plug. The matches are centered with the friction tube, which contains two matchbox or matchbook strikers glued to its sides. The tube is sized so that the match bundle cannot enter without rubbing against the sides. With the different sizes and types of matches

FRICION FUZE (WOOD OR PLASTIC)

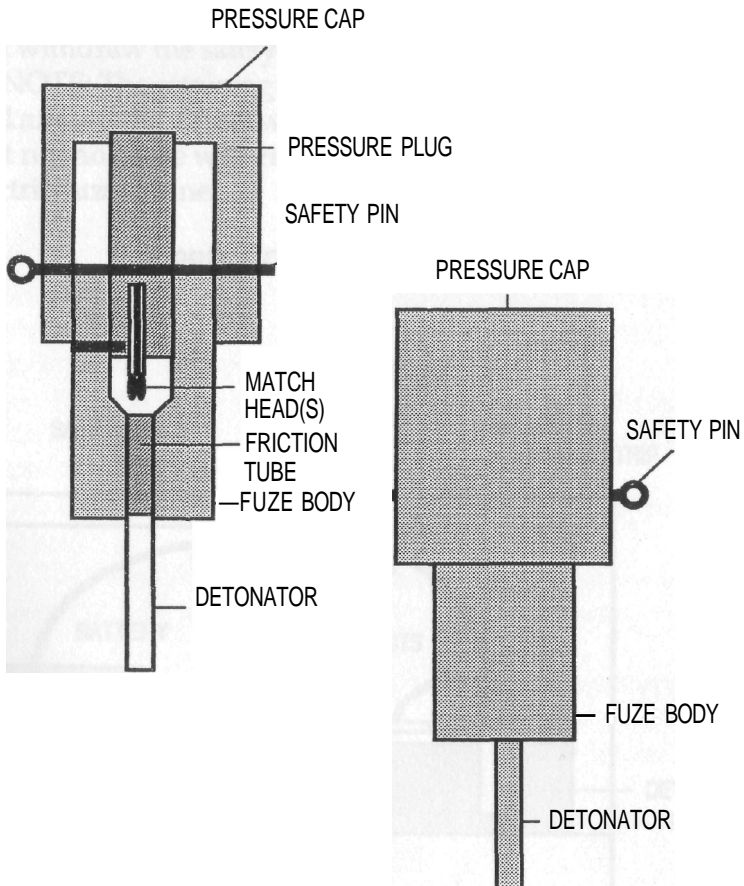

THEIR EMPLOYMENT AND DESTRUCTIVE CAPABILITIES

available, this measurement will vary. The friction tube and detonator space are filled about halfway with an easily ignited substance, such as black powder.

Do not use match heads or other chlorate-based powder! Vibration against the strikers during transit may cause premature ignition. A light tuft of tissue may be used to keep the powder in place. When pressure is applied to the pressure cap, the attached pressure plug/match assembly is forced into the friction tube, causing the matches to light. This in turn ignites the powder and detonator.

The fuze body can be made of wooden dowels, plastic pipe, or whatever is tubular. After assembly, the fuze seams should be coated with wax to waterproof them. A shear pin made of glass tube or thin solder wire is optional.

To operate, simply bury the mine and withdraw the safety pin.

NOTE: As an alternative to using three matches, you can scrape the powder off the matches, wet them with alcohol, and glue them to a piece of 1/4-inch dowel, making, in effect, one large match.

MINE CONSTRUCTION MATERIALS

AP and AT mines can and have been made from a wide variety of materials, both as improvised and production types.

The Soviets had two models, the PMK-40 (AP) and the TMB-2 (AT), that were made from cardboard. It was common Soviet practice during World War II to supply their armies with explosives, fuzes, and drawings rather than complete mines. The various commands were expected to build their own, using locally available lumber.

The Germans used an AP mine made entirely of glass called, naturally enough, the "Glasmine 43," which resembled a casserole dish.

During World War II, the Japanese favored mines made from clay or other ceramic materials. Metal cooking pots, glass jars and bottles, or even resealable metal shoe polish (Kiwi) cans have been pressed into service.

Whatever material you decide (or are forced) to use, make sure it is waterproof and will withstand the pressure necessary to cause detonation of the fuze without collapsing.

Wooden Mines

Mines constructed from common lumber are among the easiest to build—providing you possess any sort of wood-working skills at all. Soviet models 1951, TMD-44, and TMD-BAT mines are shown as examples of mines built from 1/2-inch pine boards. The explosive charge consisted of TNT demolition blocks that were fitted into the wooden box.

The 2-inch "wooden block" AP mines are even simpler. Instead of building a box to house the explosive charge, drill a large hole about three-fourths of the way through a rectangular block of lumber. The hole's diameter should snugly house one of the 75-gram explosive cylinders common to European armies, or one-half stick of dynamite.

THEIR EMPLOYMENT AND DESTRUCTIVE CAPABILITIES

TMD-44 ANTITANK MINE

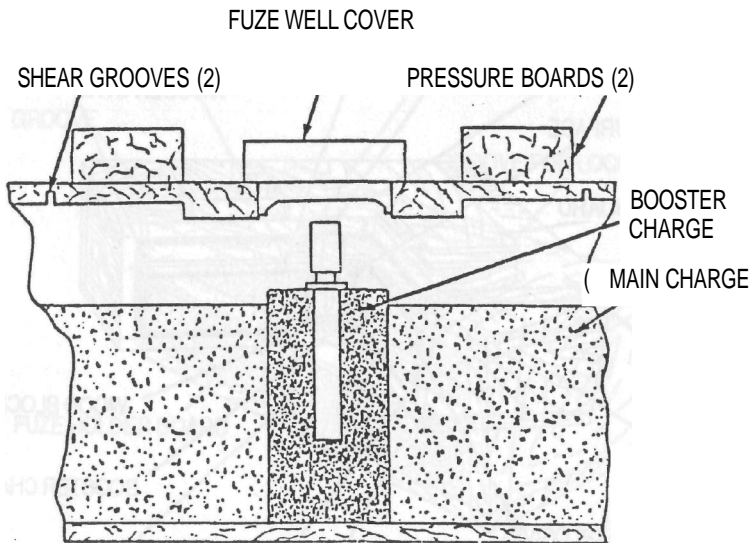
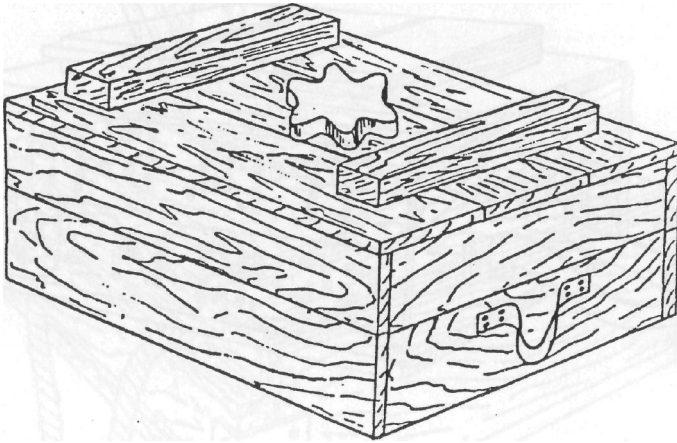

IMPROVISED LAND MINES

TMD-B ANTTANK MINE

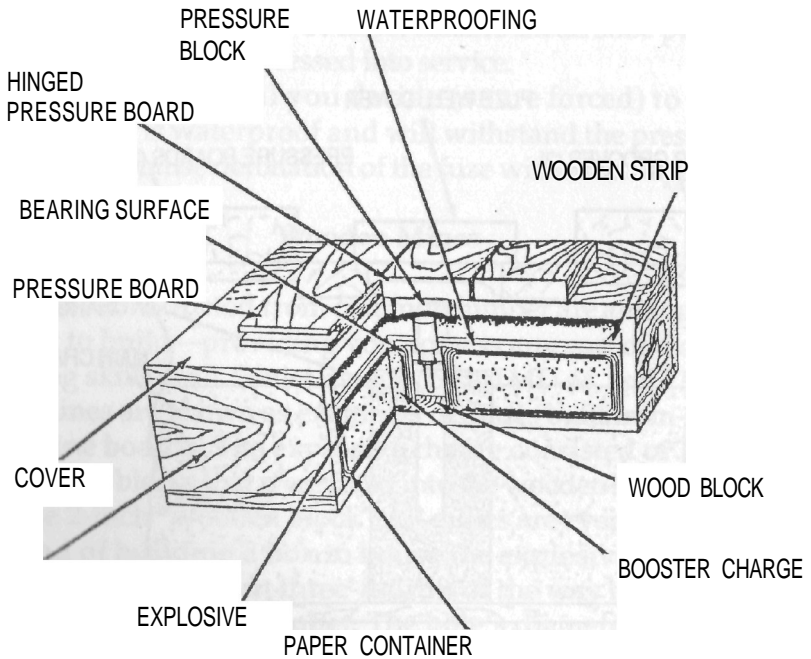
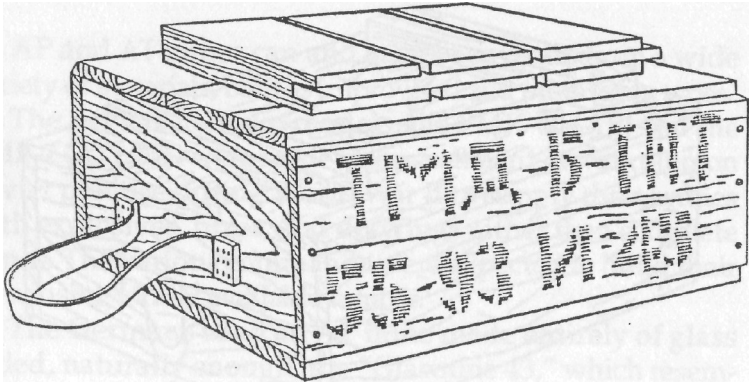

THEIR EMPLOYMENT AND DESTRUCTIVE CAPABILITIES

ANTITANK MINE, MODEL 1951

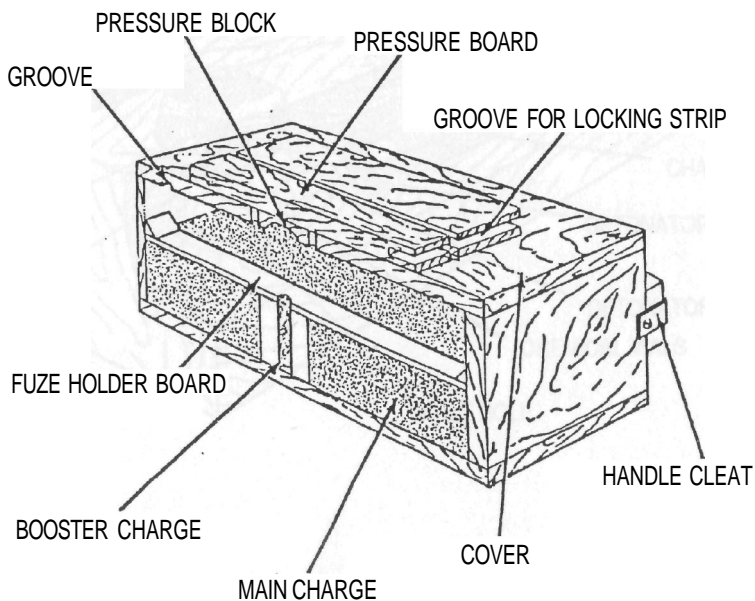
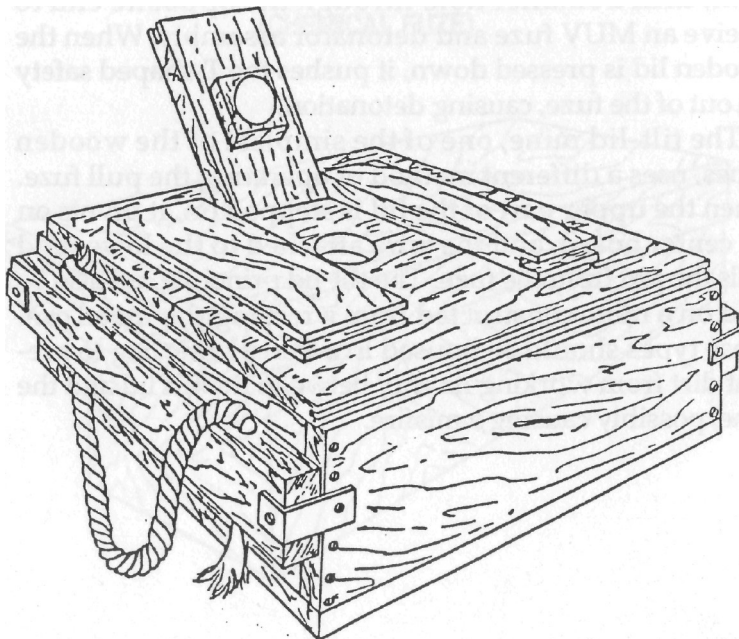

IMPROVISED LAND MINES

Next, drill a smaller hole through the opposite end to receive an MUV fuze and detonator assembly. When the wooden lid is pressed down, it pushes the T-shaped safety pin out of the fuze, causing detonation.

The tilt-lid mine, one of the simplest of the wooden mines, uses a different method of operating the pull fuze. When the upper part of the lid is stepped on, it pivots on the center board, and the wire attached to the lower end pulls the pin from the fuze. The tilt-lid principle can also be used on a mine constructed from a rectangular metal can. These types should be housed in a thin plastic bag to prevent dirt from working its way between the tilt lid and the mine, possibly causing a misfire.

THEIR EMPLOYMENT AND DESTRUCTIVE CAPABILITIES

**WOODEN BLOCK AP MINE
(CHEMICAL FUZE)**

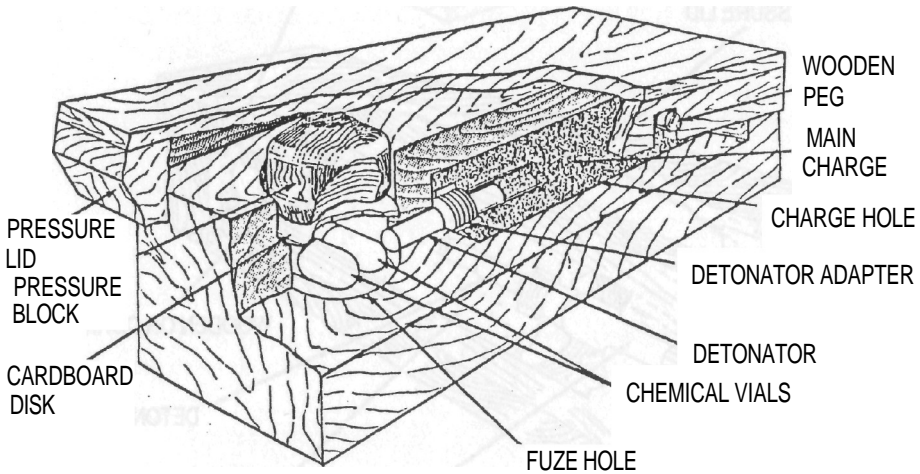
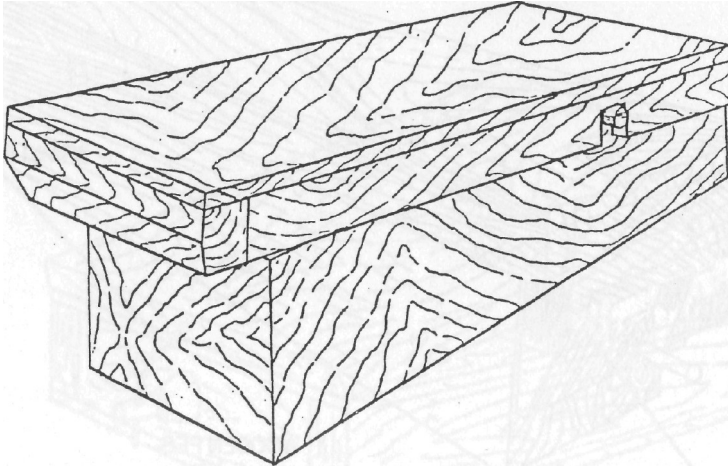

IMPROVED LAND MINES

**WOODEN BLOCK AP MINE
(MECHANICAL FUZE)**

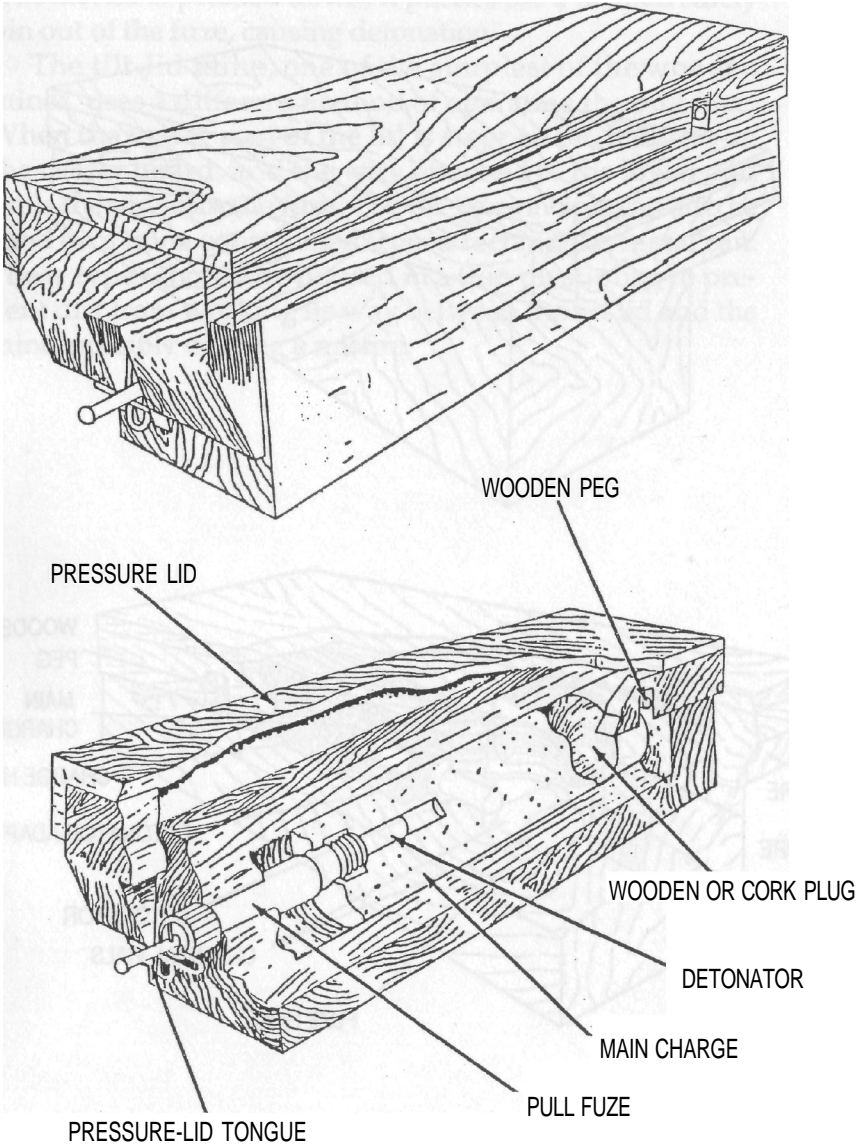

THEIR EMPLOYMENT AND DESTRUCTIVE CAPABILITIES

TILT-LID AP MINE

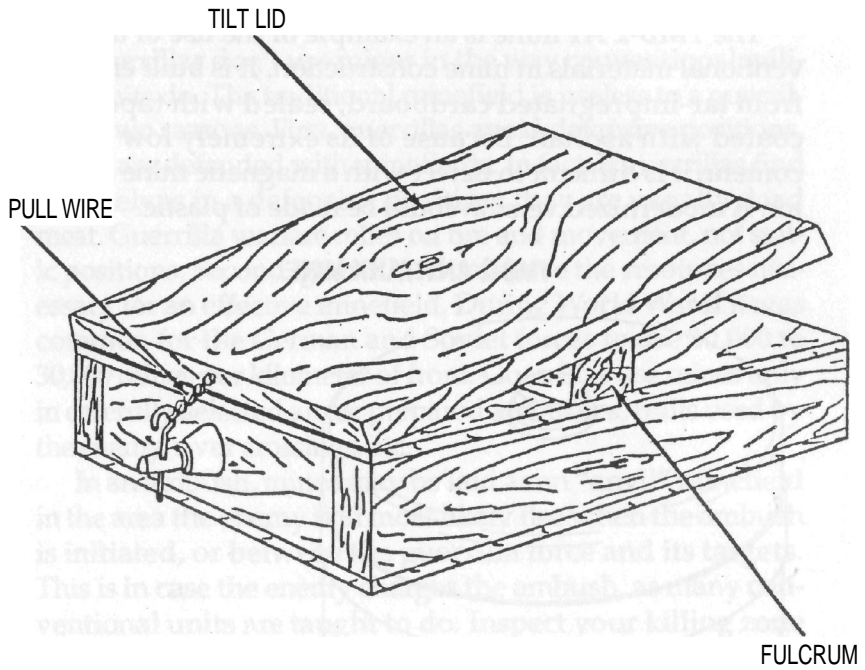

TMB-2-TYPE ANTITANK MINE

The TMB-2 AT mine is an example of the use of unconventional materials in mine construction. It is built entirely from tar-impregnated cardboard, sealed with tape, and coated with asphalt. Because of its extremely low metal content, it is difficult to detect with a magnetic mine detector. A modernized version could be made of plastic.

TMB-2 ANTITANK MINE

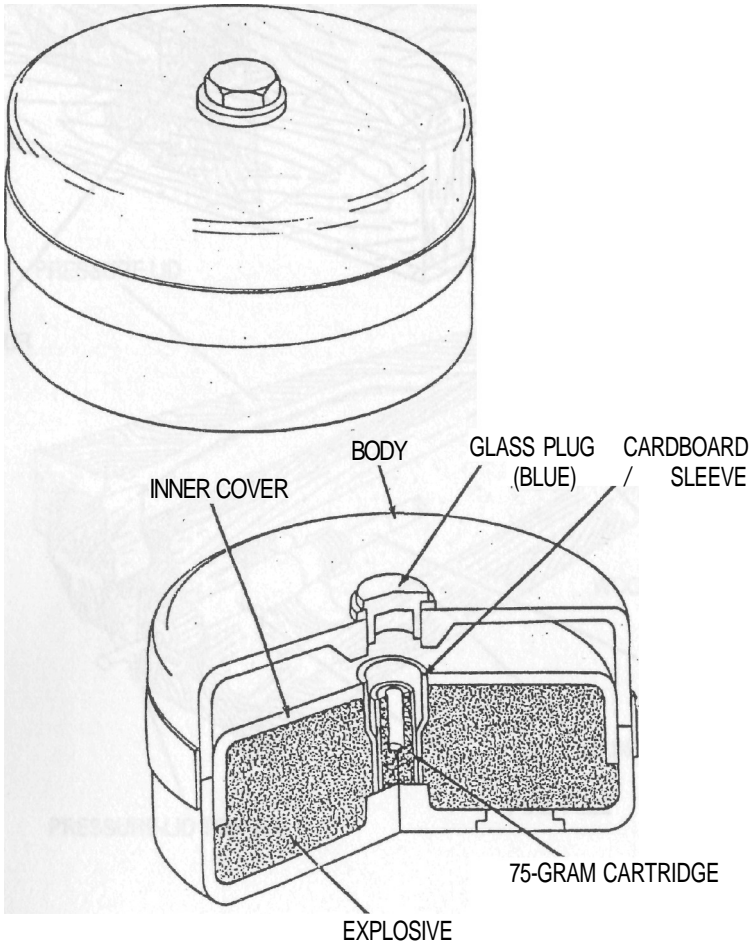

GUERRILLA EMPLOYMENT OF MINES

Guerrillas don't use mines in the way conventional military units do. The traditional minefield is useless to a guerrilla for two reasons. First, guerrillas avoid defensive positions, which are defended with minefields. In fact, if guerrillas find themselves in a defensive position, they are usually dead meat. Guerrilla warfare relies on fire and movement, not static positions. Second, guerrillas don't have the resources necessary for an effective minefield. During World War II it was common for the German and Soviet forces to use 20,000 to 30,000 mines per kilometer of front. Guerrillas use mines only in carefully selected areas: prepared ambushes, trails used by the enemy, river crossings, etc.

In an ambush, mines may be laid as an "anvil" minefield in the area the enemy will most likely flee when the ambush is initiated, or between the guerrilla force and its targets. This is in case the enemy charges the ambush, as many conventional units are taught to do. Inspect your killing zone from your target's point of view. Where would you seek cover? How would you approach the firing positions? This is where your AP mines will do the most good.

If the area is free of civilians wandering about, you can mine all the trails and clearings, or any likely bivouac spot. Where you employ mines depends on your opponent's habits. The most cunningly made mine is useless if your target never visits the site. Salvadorean guerrillas laid an ingenious mine pattern at an army firing range that was outside the perimeter of its base. The traps consisted of six mines disguised as small boulders, containing about a kilo of high explosive each. They were arranged in a semicircular pattern around a clearing with the firing device in the center.

MINELAYING TRICKS

The first trick of laying mines is to find an area that your enemy will pass. For AT mines, this usually means a roadway or trail of some sort. Dirt roads are okay for this activity. Bury the mines in the tracks left by previous vehicles. Subsequent traffic will tend to follow them. An old Vietcong trick was to bury the mines and roll a tire over them to duplicate the tracks.

My all-time favorite location for landmines is a gravel road. Not only is it so much easier to return the surface to its original appearance, the texture of a gravel roadbed drives the newer nonmetallic mine detectors (those that read variances in the soil density) berserk.

Another trick to foil nonmetallic detectors is to bury empty bottles, chunks of wood, or things like that. They will all cause the bell to ring. To defeat older metal detectors, bury scrap metal all around the area.

The newest phase in this seesaw battle is the explosives "sniffer," which detects the chemical odor of nitrogen-based explosive compounds. This detector has proven very effective at sniffing out improvised explosive devices (IEDs), but many of the newer production mines have hermetically sealed plastic bodies. Whether or not the explosive can be detected through this barrier remains to be seen.

To defeat the sniffer, make a powder of some TNT or ammonium nitrate and sprite it around the area. The sniffer can't tell how much explosive there is, only that it is present. If a lot of road repair goes on in your area of operation, you may want to assist the local government by filling in some of the potholes yourself. Place your mine in the hole and cover it with a pasty mixture of used motor oil and sand (this may be recognized by some as the key elements of the old "driveway paver's scam"). Properly mixed, this goop bears a remarkable resemblance to asphalt, even

THEIR EMPLOYMENT AND DESTRUCTIVE CAPABILITIES

under close scrutiny. However, rain will wash it away, so it should be used in dry weather.

If mines are laid in snow or soft, marshy ground, you will need to put a support board under them to keep the pressure plate at proper level. On soft, wet earth, the pressure plate doesn't have to be above the surface, but on hard, solid ground it does. A good way to judge whether to put the plate above or below the surface is to inspect the tracks of previous traffic and see how far down the soil is compressed. In any case, the pressure plate must be carefully camouflaged to avoid detection. This is especially important for AP mines. Tankers have a restricted field of vision; infantrymen don't.

Harassing mines may be laid anywhere the enemy travels and are especially good in "safe" areas. If minesweeping has to be done everywhere the enemy travels and not just in the combat zones, it will tie up more of his troops and be more disruptive than simple ambush mining. This brings to mind the old trick, first used in the Spanish Civil War, of placing suspicious objects in the roadway. A Republican unit, retreating from Franco's oncoming tanks, placed several soup plates in the road. The tank commander, fearing they were mines, refused to cross the area and lost several hours finding a route around them. In the meantime, the Republicans made a safe getaway.

Probably every tanker in the world knows this story, but it still introduces an element of risk. What if there are mines? To make things interesting, pull this trick a couple of times, then put some real mines under the objects. Or do it the first time. If nothing else, place some horizontal penetration mines at the spot at which the enemy will likely stop while deciding what to do. You can have a lot of fun with this trick.

Along the same line, you can place a suspicious object, such as a cardboard box, in the road just around a blind curve. When the target rounds the corner and spots the box, he will most likely swerve onto the shoulder to avoid it if he

can't stop in time. This is where you place the mines. This is another good way of dealing with the problem of paved roads. After you've pulled this one a few times, put a real mine in the box. After a while, the enemy will slow down at all blind corners. You can then start using horizontal mines (discussed on page 69) or command-detonated charges, or use this ruse as the initiation point for an ambush. Then again, leaving empty boxes by themselves in these areas can cause no end of amusement (psy war). The goal is total unpredictability.

A commonly taught method of dealing with a mine is to use a grappling hook and rope to lift it free from the ground. If the mine has an "antilift" or booby-trap device under it, it will explode without causing casualties. A handy trick (one of the class known as "gotchas") is to find the best area of cover within the prescribed range (30 to 50 meters) of this technique and place a couple of AP mines there. Try to find the spot you would hide in if you were using this method of mine removal.

ANTIPERSONNEL MINES

AP mines are smaller than AT mines. Explosive content varies from 1 ounce of tetryl used in the M-14 mine to 8 ounces of TNT used in the Soviet PMN series. The smaller AP mines—such as the M-14, the British "ointment box," or the Soviet PMK-40—are known as "toe poppers." The tiny charge of explosive they contain is capable of severely injur-

IMPROVED MINE MADE FROM GLASS JAR (BUCK FUZE UTILIZED)

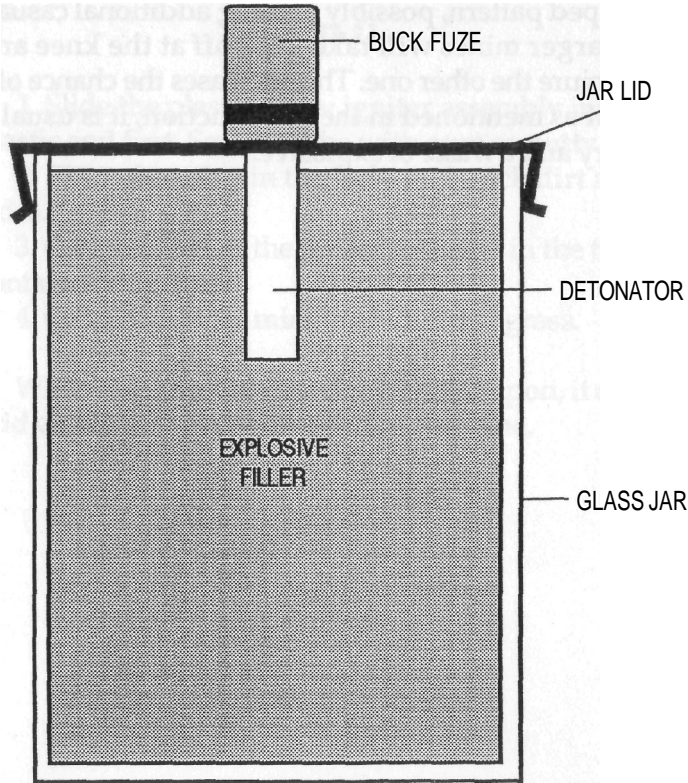

Before loading this mine with molten explosives, be sure to preheat the glass jar in a hot-water bath to keep it from breaking when the filler is added.

ing a man's foot or, in some cases, taking it off at the ankle.

Toe poppers are especially handy in urban areas because they are so easy to conceal. They've been hidden under doormats or stair steps, and even taped to the wall behind a door to be detonated when the doorknob strikes them. They usually injure only the person who actually steps on them, but you can increase the wounding effect of the mine by following a few simple steps.

Securely anchor the mine in a shallow, bowl-shaped pit and fill the area around the sides with small stones or gravel. When the mine detonates, the stones will be projected in a cone-shaped pattern, possibly causing additional casualties. The larger mines will take a leg off at the knee and probably injure the other one. This increases the chance of a fatality, but as mentioned in the introduction, it is usually unnecessary and a waste of explosive.

SOUP-CAN AP MINE

1. Open and clean out a 10-ounce can.
2. Punch a 3/8-inch hole in the lower side, about 1/4 inch from the bottom.
3. Glue the pressure-dowel tube to the side of the can, exactly opposite the hole.
4. Glue the detonator tube in place.
5. Fill the can with high explosive up to 1/2 inch from the top.
6. Press closure disk in place and seal.

To Use

1. Slide the plastic-straw igniter assembly into the tube, plastic end first. Seal the tube with gum or putty.
2. Place the mine in the hole and pack dirt around the sides.
3. Carefully insert the pressure dowel in the tube until it contacts the igniter.
4. Camouflage the mine with dirt and grass.

When the pressure dowel is stepped upon, it crushes the acid vial in the igniter, detonating the mine.

IMPROVISED LAND MINES

SOUP CAN ANTIPERSONNEL MINE

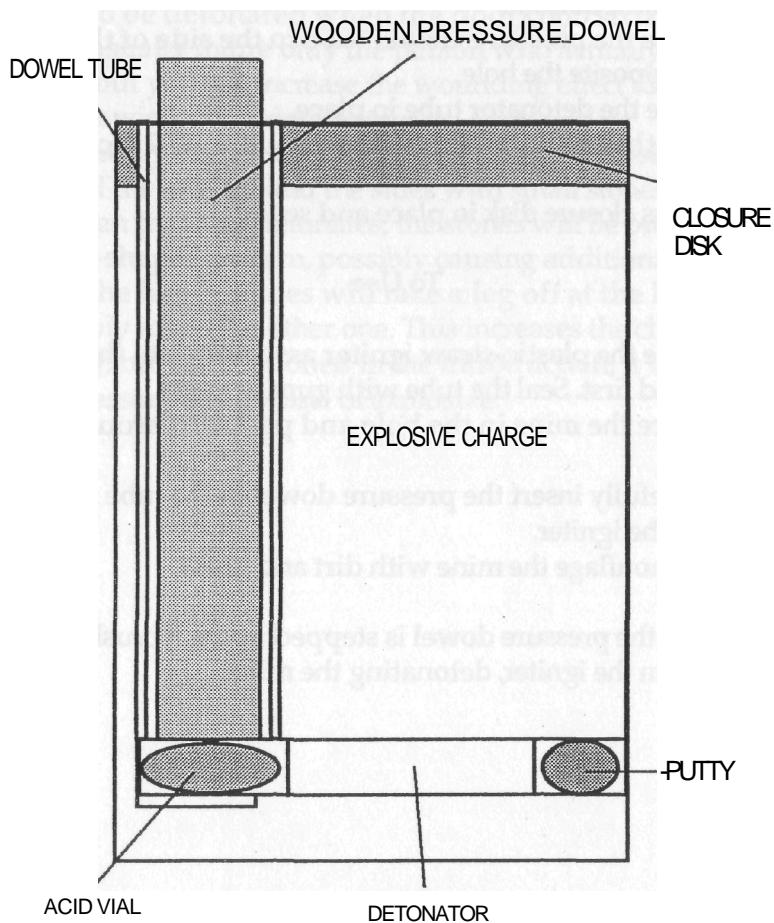

This mine can be made more lethal by replacing the top half of the explosive charge with metal fragments, such as nuts, bolts, ball bearings, or whatever is available.

THEIR EMPLOYMENT AND DESTRUCTIVE CAPABILITIES

WOODEN BOX AP MINE

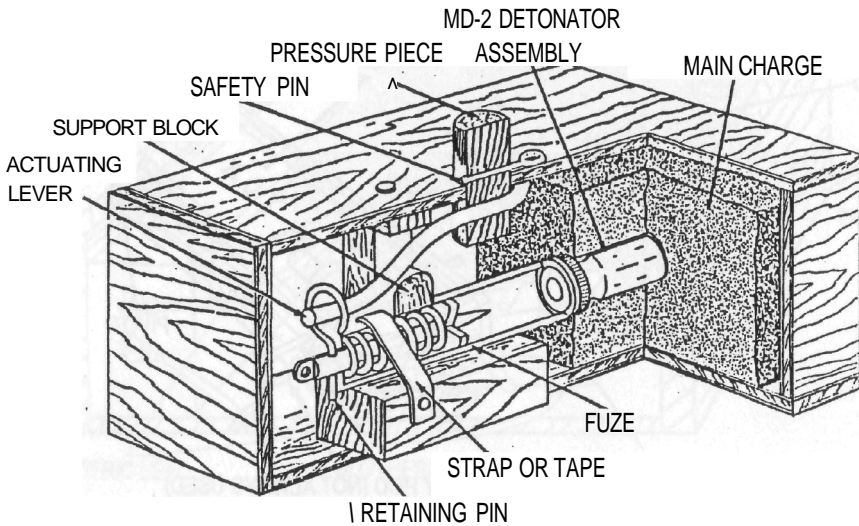
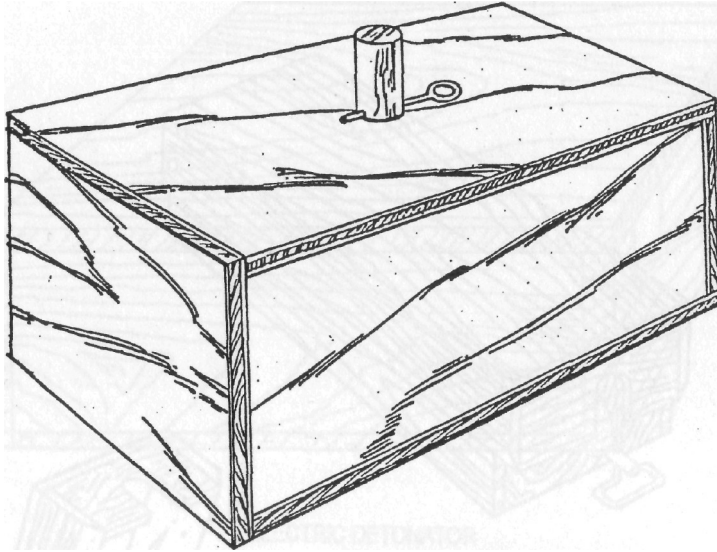

This mine illustrates another application of the MUV-type pull fuze. A weight pressing on the pressure piece causes the actuating lever to pivot, pulling the pin from the fuze and detonating the mine.

IMPROVISED LAND MINES

PMD-6APMINE

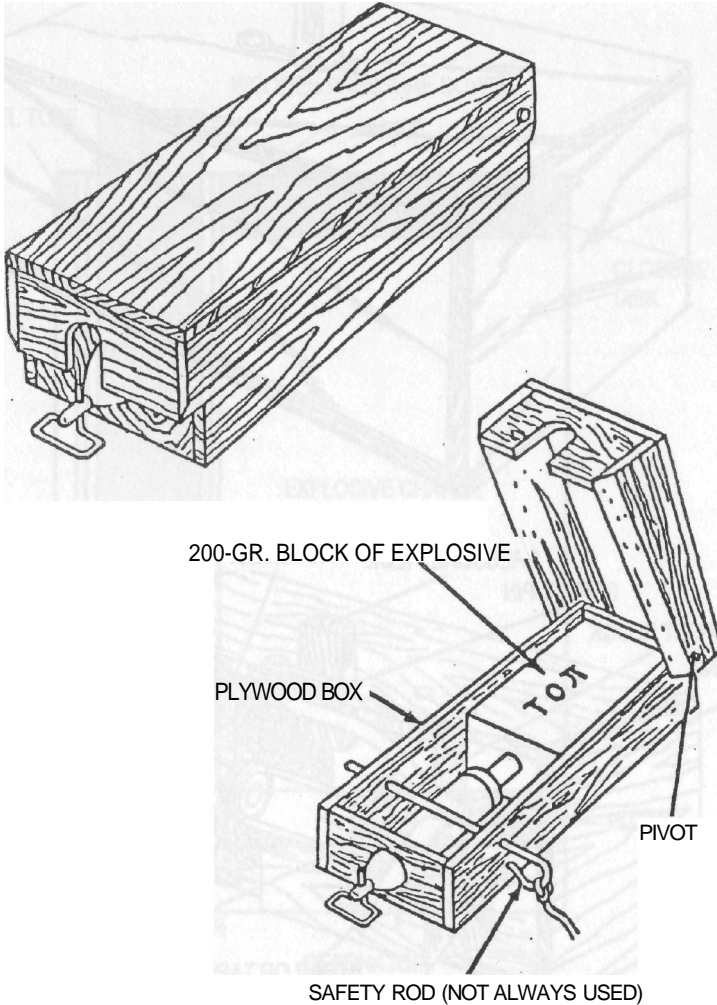

This is a classic example of a type known as the "Shoemine" (a corruption of the German term "schumine"). The mine boxes average about 7 to 3 inches long by 3 inches wide, and usually hold around 6 to 8 ounces of high explosive. It uses the MUV-type fuze and is easily built from common lumber and plywood. The lid pivots on its pins and presses down on the T-shaped "wings" of the safety pin, withdrawing the pin and firing the fuze.

THEIR EMPLOYMENT AND DESTRUCTIVE CAPABILITIES

CLOTHESPIN ELECTRIC AP MINE

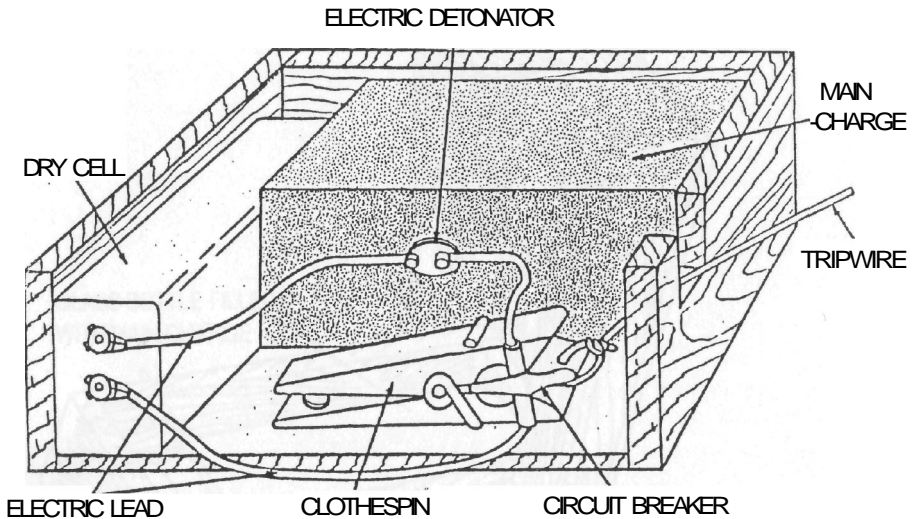
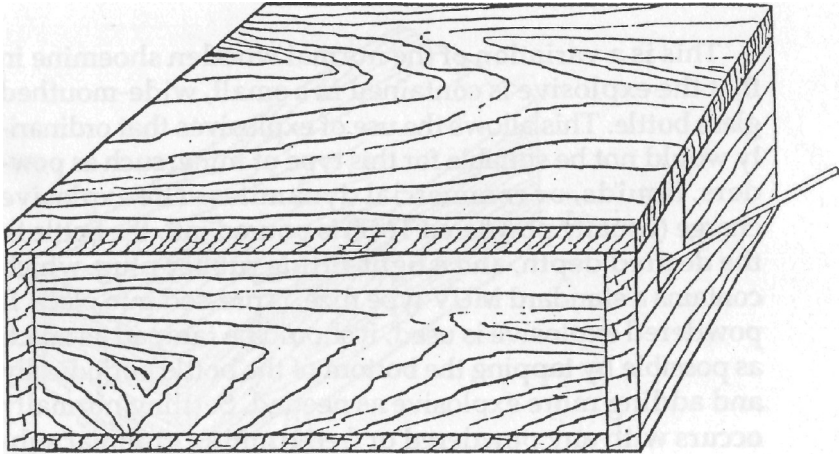

This basic electric-fuzed mine was first used by Soviet partisan forces in World War II, and it has been copied by innumerable guerrilla armies since. The trip wire is strung across a trail or other likely approach. When passing traffic trips the wire, it removes the circuit breaker from the jaws of the clothespin, which then closes and completes the circuit.

PMD BOTTLE MINE

This is a variation of the normal wooden shoemine in that the explosive is contained in a small, wide-mouthed glass bottle. This allows the use of explosives that ordinarily would not be suitable for this type of mine, such as powders, liquids, or commercial dynamites. The explosive charge (usually powdered TNT) is poured into the bottle to the desired depth, and a tight-fitting rubber plug, which contains a standard MUV-type fuze, is pressed into place. If powdered explosive is used, it should be tamped as much as possible by tapping the bottom of the bottle periodically and adding more explosive as needed. Settling normally occurs with any powdered or free-running granular substance, and if this is excessive, it may lower the level of the explosive to below that of the detonator, resulting in a misfire or weak detonation.

PMD BOTTLE MINE

This is a variation of the normal wooden shoemine in that the explosive is contained in a small, wide-mouthed glass bottle. This allows the use of explosives that ordinarily would not be suitable for this type of mine, such as powders, liquids, or commercial dynamites. The explosive charge (usually powdered TNT) is poured into the bottle to the desired depth, and a tight-fitting rubber plug, which contains a standard MUV-type fuze, is pressed into place. If powdered explosive is used, it should be tamped as much as possible by tapping the bottom of the bottle periodically and adding more explosive as needed. Settling normally occurs with any powdered or free-running granular substance, and if this is excessive, it may lower the level of the explosive to below that of the detonator, resulting in a misfire or weak detonation.

THEIR EMPLOYMENT AND DESTRUCTIVE CAPABILITIES

PMD BOTTLE MINE

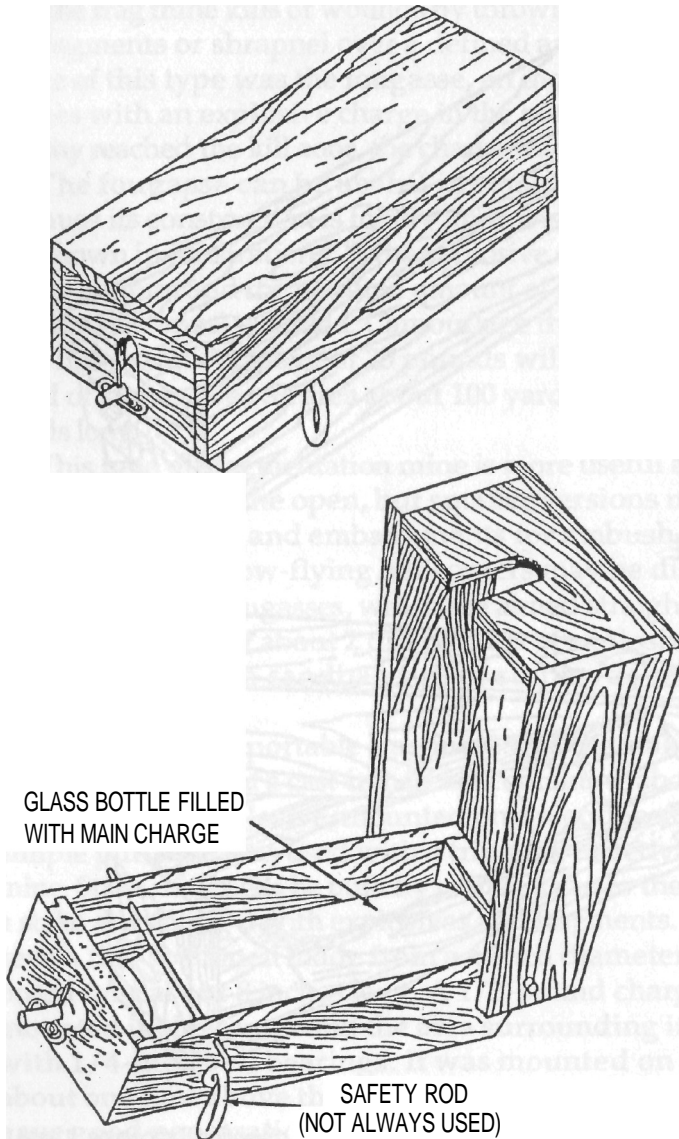

IMPROVISED LAND MINES

PMD MORTAR SHELL MINE

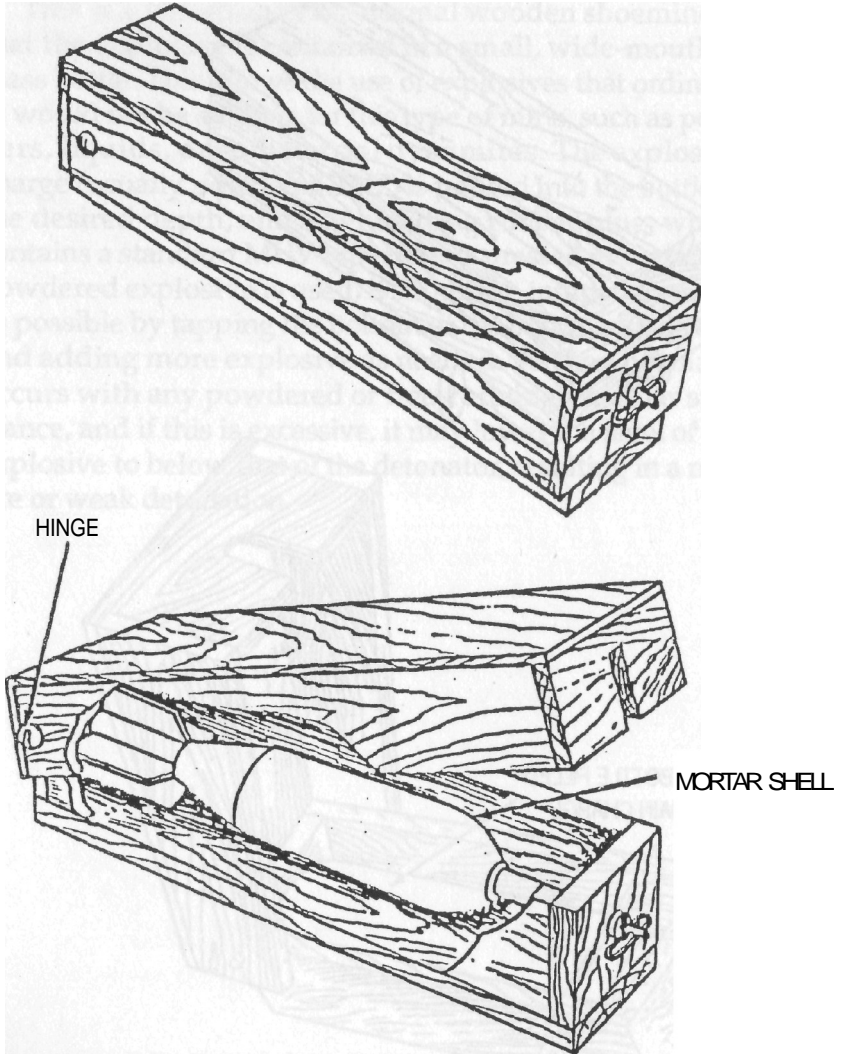

The PMD mortar-shell mine is another variation of the conventional shoemine. It uses a small caliber (usually 60mm) mortar shell as its explosive shell, and the mortar's fragmentation characteristics make it more effective than the usual mine of its type.

FRAGMENTATION MINES

The frag mine kills or wounds by throwing out a pattern of fragments or shrapnel over a defined area. The earliest mine of this type was the fougasse, an inclined pit full of stones with an explosive charge in the bottom. When the enemy reached the kill zone, the charge was detonated.

The fougasse can be useful in some circumstances because its construction is totally improvised. A pit is dug (as shown in illustration 22), the explosive charge is placed in the bottom, and the required amount of fragments (usually small stones) is added. Camouflage the top of the pit, and it is ready. A charge of 25 pounds will propel a cubic yard of stones over an area about 100 yards wide and 200 yards long.

This type of fragmentation mine is more useful against massed troops in the open, but smaller versions may be dug into hillsides and embankments for ambushes (see illustration 23). Low-flying helicopters may be discouraged by vertical fougasses, which are aimed straight up in the air. A charge of about 2 to 3 pounds of explosive may be placed under a sandbag full of stones, as sort of a portable fougasse.

The first really portable frag mine was the stake-type mine. It consisted of a cast-iron jacket containing about 1/4 pound of high explosive, mounted on a wooden stake. A simple pull fuze was used with a trip wire to activate the mine. Stake mines can be built by nailing a can to the top of a stake and filling it with explosives and fragments. I have seen a fine specimen made from a 4-inch diameter cardboard tube about 8 inches long. A 1/3-pound charge was mounted in the center and the area surrounding it filled with 1/4-inch ball bearings. It was mounted on a post about one foot above the ground and, when detonated, gave good penetration out to 100 yards, though at this range the pattern got a little thin.

IMPROVISED LAND MINES

These types of mines are known as omnidirectional, meaning that the fragments are propelled equally in all directions. Unidirectional mines, i.e., the claymore type, are really better suited for most applications.

The most basic claymore-type mine is the grapeshot charge, which consists of a tin can with metal fragments packed in one end and a high-explosive charge in the other (see the illustration on page 42). The usual ratio is one part explosive to four parts fragments, by weight, and the mines can be made in any size needed, according to the materials at hand and the range required.

Claymore-type charges can be concealed in bushes, tall grass, or even hung in trees, aimed downward. The Selous Scouts used the last technique effectively in Rhodesia in the late 1970s to wipe out guerrilla troops traveling in the backs of open trucks.

In an urban setting, claymores may be concealed in the eaves of houses, aimed at a downward angle to cover the approach. If hooks are attached to the mine, it may be hung behind a curtain facing the kill zone. One of the most imaginative hiding spots is in a glass-fronted newspaper machine, behind the first copy.

SIMPLE FOUGASSE

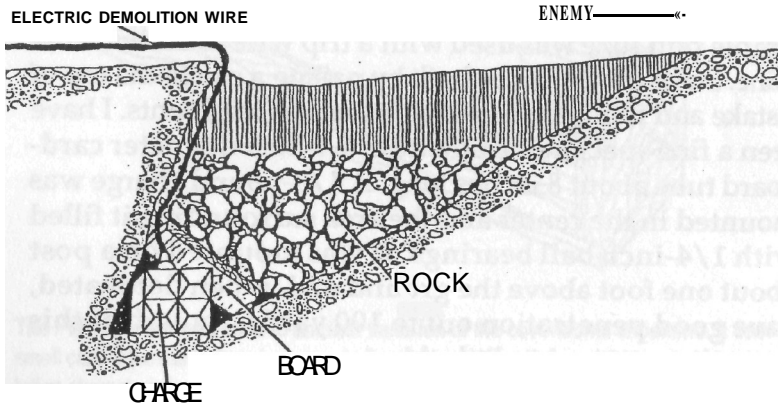

THEIR EMPLOYMENT AND DESTRUCTIVE CAPABILITIES

HILLSIDE FOUGASSE

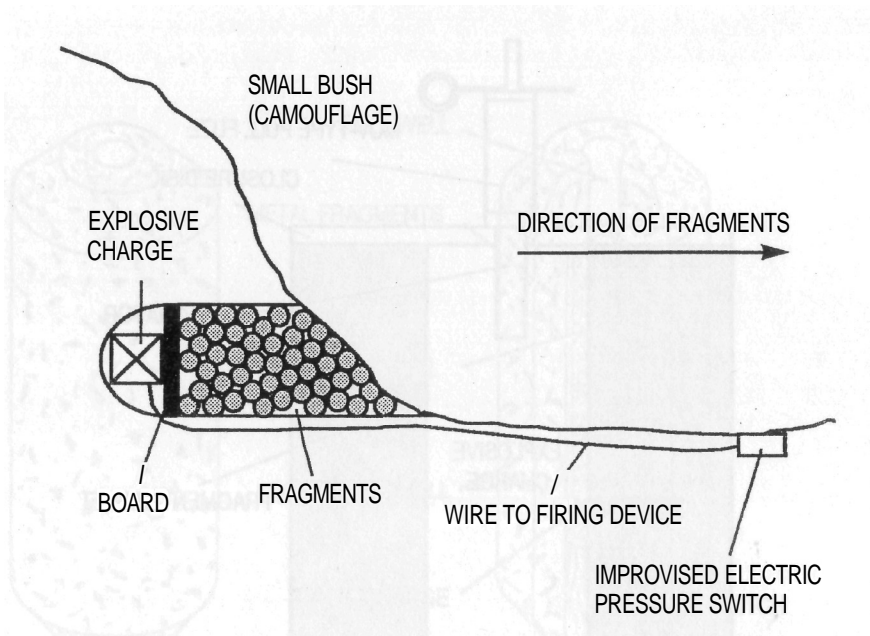

This hillside fougasse may be command-detonated if desired. If only low explosive or propellant is available, the charge can be contained within a steel pipe or other tube, such as a shotgun. However, this will reduce the range. For maximum coverage, this mine is best positioned at a bend in a trail.

IMPROVISED LAND MINES

BASIC STAKE-TYPE MINE

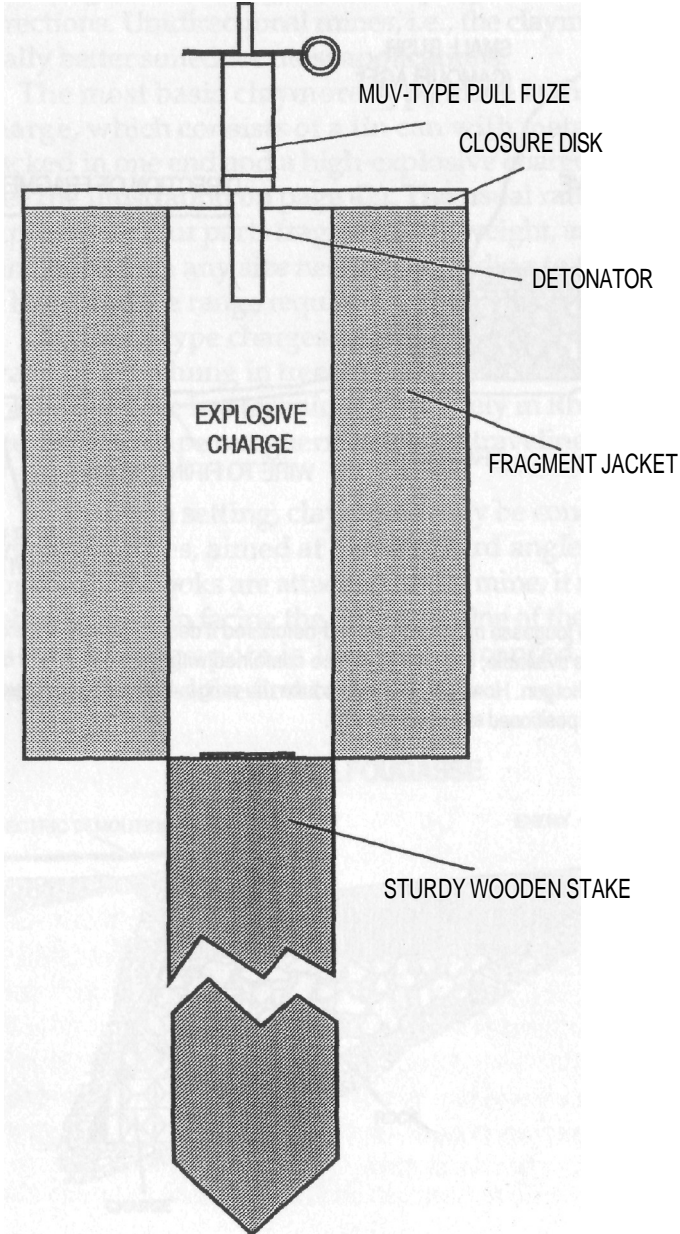

THEIR EMPLOYMENT AND DESTRUCTIVE CAPABILITIES

GERMAN CONCRETE STAKE MINE

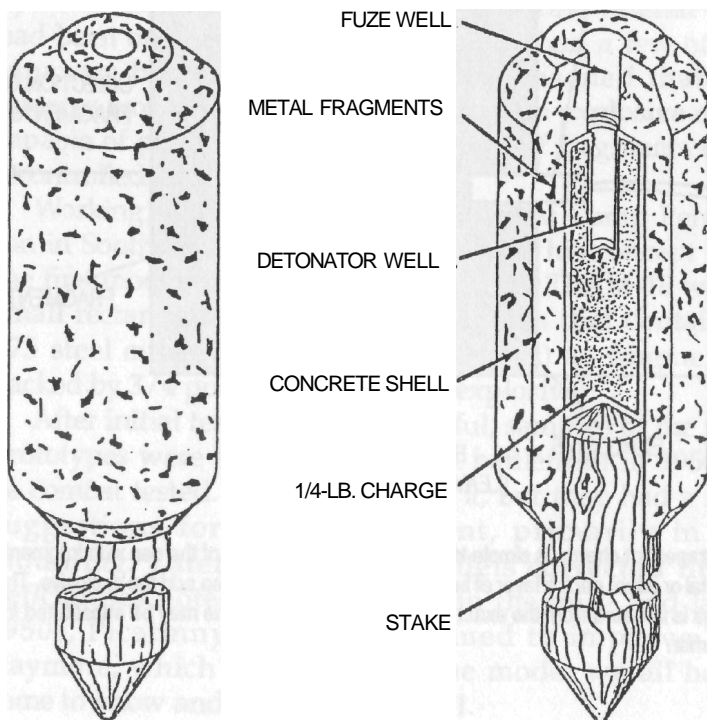

This mine consists of a small explosive charge enclosed in a jacket of fragments that is cast in a weak concrete binder. Epoxy, plaster, or plastic could be used in place of the concrete. The binder serves only to hold the fragments together until the 1/4-pound of high-explosive charge blows them apart. The fragments can be anything from ball bearings to nuts and bolts. The Vietcong used to comb the battlefield for old fragments from exploded artillery rounds, and in many areas of Vietnam finding these was easy. As with all stake mines, this mine works best in areas of high grass or other light vegetation. If the mine is to be in place for a few days only, a small bush can actually be wired to the mine as camouflage. After a couple of days, the bush will begin to wilt and stand out from the rest of the vegetation. Make sure the cover does not interfere with operation of the fuzing system. A stake mine using this charge and configuration has a lethal radius of about 8 to 10 meters.

GRAPESHOT CHARGE

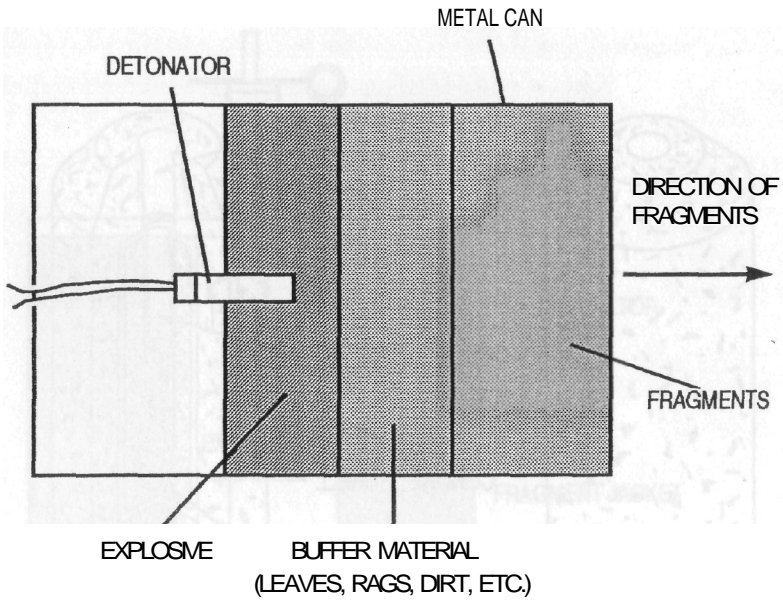

The grapeshot charge is simple to construct. Fill the bottom of the can with fragments of metal or such, pack a layer of buffer material over them, then add the explosive. The charge is initiated from the exact rear center. Plaster of paris may be substituted for the buffer.

CLAYMORE MINES

The claymore AP mine was invented in the late 1940s by Norman MacLeod, a World War II marine veteran who had been on the receiving end of more than a few of the Japanese banzai attacks. MacLeod reasoned that the infantry would need a small, aimable high-explosive mine capable of projecting an intense swarm of fragments over a controlled area.

Working with the U.S. Marine Corps at Camp Pendleton in Southern California, he developed his concept into the first model of the claymore, the M-18. The M-18 was a small rectangular box made of fiberglass that contained 675 steel cubes (3/16 inch in diameter) as fragments, backed by 3/4 pound of C-3 plastic explosive.

After initial tests proved successful, samples of the first prototypes were sent to the Korean battlefield in 1950 to be combat tested. The troops loved it, but they had a few suggestions for its improvement, primarily in its mounting. Later production models corrected these deficiencies noted by the troops. In the mid- and late-1950s, Picatinny Arsenal continued to improve the claymore, which culminated in the model we all have come to know and love—the M-18A1.

The M-18A1 was made slightly larger and heavier than the M-18, with an improved mounting system, but the greatest improvement was in the payload. The 675 steel cubes were replaced by 700 steel balls of the same diameter, which gave better flight characteristics, and the 3/4 pound charge of C-3 gave way to 1 1/2 pounds of C-4. These changes resulted in a 40-percent increase in the depth of the killing zone (50 meters as opposed to 30 meters for the M-18). The firing device was also changed from the simple, but patently unsafe, battery pack to a small impulse generator.

Many countries have used the basic claymore concept

during the last twenty years, either as a direct copy (Korea, South Africa) or, in many cases, as a greatly enlarged model for improved range (see chart below). All owe their origins to MacLeod's inspiration in the Pacific jungles during World War EL

CLAYMORE-TYPE FRAGMENTATION MINES

| Model | Weight of Mine | Weight of Explosive | Type of Explosive | Effective Range | Country of Origin |
|--------------|-----------------------|----------------------------|--------------------------|------------------------|--------------------------|
| Arges M80 | 3 kg. | 1.3 kg. | PETN | 50 m. | Austria |
| SMI 20/1C | 1.9 kg. | .9 kg. | Comp. B | 50 m. | Austria |
| SMI 21/11C | 20 kg. | 11.5 kg. | Comp. B | 150 m. | Austria |
| Maped F-1 | 1kg. | ? | P.E. | 40 m. | France |
| FFV 013 | 20 kg. | ? | ? | 150 m. | Sweden |
| Padmine | 1.26 kg. | ? | ? | 50 m. | UK |
| M-18A1 | 1.58 kg. | .682 kg. | C-4 | 50 m. | USA |
| MRUD | 1.5 kg. | .9 kg. | P.E. | 50 m. | Yugoslavia |
| P5 MARK 1 | 1.6 kg. | ? | ? | 50 m. | Pakistan |
| Shrapnel | 1.6 kg. | .680 kg. | P.E. | 50 m. | S. Africa |
| Mine No. 2 | | | | | |

A simple peep sight for claymore-type mines may be made from a short piece of metal tube, about 1/4 inch in diameter and 3 inches long. Mounted on top of the mine, the peep sight is sighted through to the center of the kill zone. Good accuracy can be obtained out to around 30 meters. For longer ranges, use a 1/2-inch-wide tube of the same length and mount cross hairs in both ends. Hold your eye about 6 inches away from the tube and line up both sets of cross hairs.

THEIR EMPLOYMENT AND DESTRUCTIVE CAPABILITIES

Feb. 28, 1961

N. A. MacLEOD

2,972,949

ANTI-PERSONNEL FRAGMENTATION WEAPON

Filed Jan. 18, 1956

3 Sheets-Sheet 1

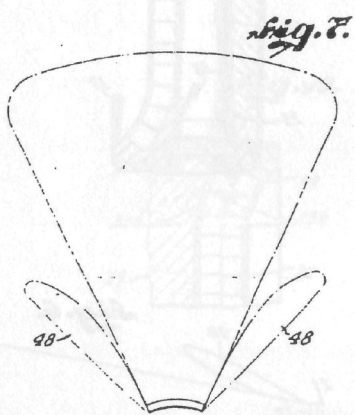
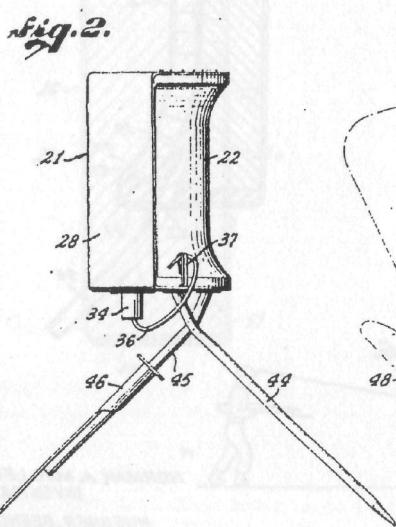
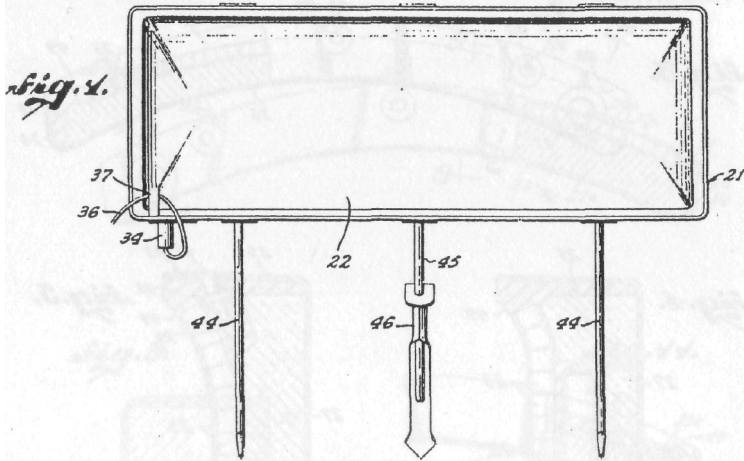

NORMAN A. MAC LEOD,
INVENTOR.

HUEBNER, BEEHLER,
WORREL & HERZIG,
ATTORNEYS.

By Warren T. Jessup

IMPROVED LAND MINES

Feb. 28, 1961

N. A. MACLEOD

2,972,949

ANTI-PERSONNEL FRAGMENTATION WEAPON

Filed Jan. 18, 1956

3 Sheets-Sheet 2

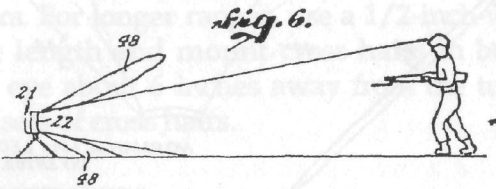
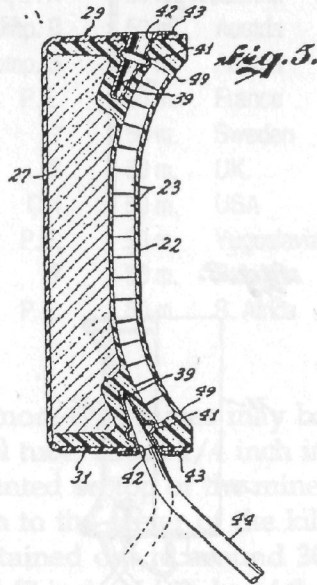
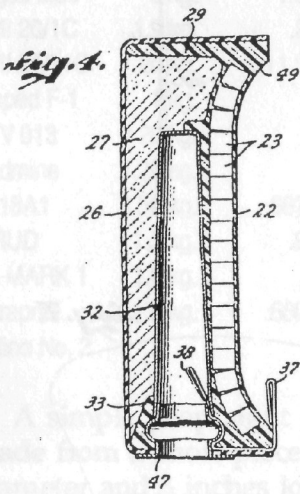
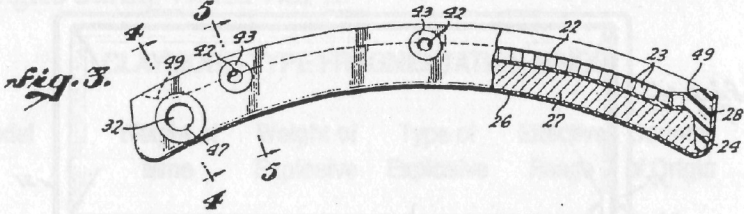

NORMAN A. MACLEOD,
INVENTOR.

HUEBNER, BEEHLER,
WORREL & HERZIG,
ATTORNEYS.

BY Warren T. Jessup

THEIR EMPLOYMENT AND DESTRUCTIVE CAPABILITIES

Feb. 28, 1961

N. A. MacLEOD

2,972,949

ANTI-PERSONNEL FRAGMENTATION WEAPON

Filed Jan. 18, 1956

3 Sheets-Sheet 3

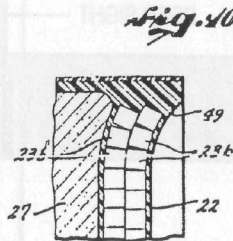
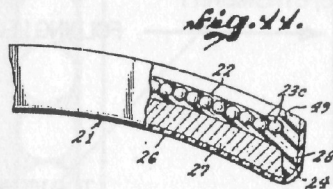
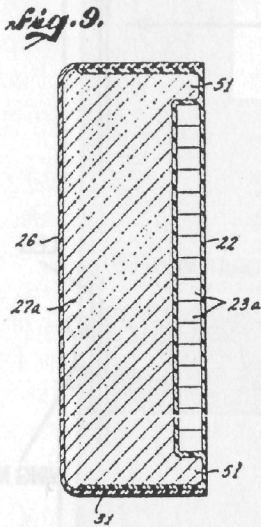
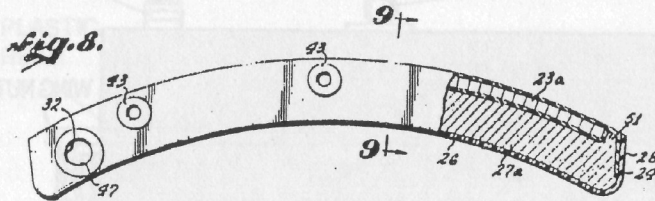

NORMAN A. MAC LEOD,
INVENTOR.

HUEBNER, BEEHLER,
WORREL & HERZIG,
ATTORNEYS.

BY *Warren T. Jessup*

HOMEMADE CLAYMORE

FRONT VIEW

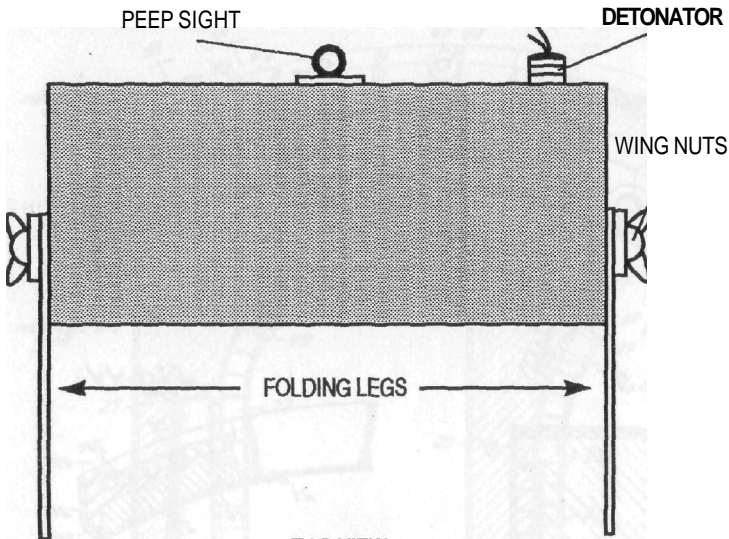

TOP VIEW

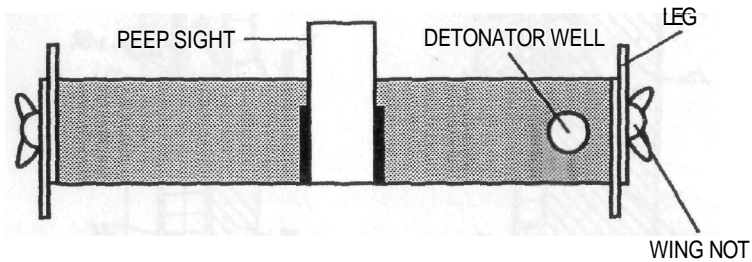

The mine on the facing page is built from a simple plastic box, about 8 inches long by 3 inches high by 1 1/2 inches thick. The front half has a layer of BBs set in plastic resin. The rest of the section is packed with plastic explosive at least as heavy as the fragments, preferably twice as heavy. Two bolts set in the lower part of the case serve as mounting points for the legs, which are simple wood or plastic strips about the size and shape of tongue depressors. Wing nuts are used to adjust the legs. A detonator well is prepared in the top corner and covered with a thin piece of tape until needed. The pattern of the homemade mine is not as wide as that of the claymore since its body is not curved, but it will still provide a dense mass of fragments for a respectable range.

THEIR EMPLOYMENT AND DESTRUCTIVE CAPABILITIES

**HOMEMADE CLAYMORE
SECTIONED SIDE VIEW**

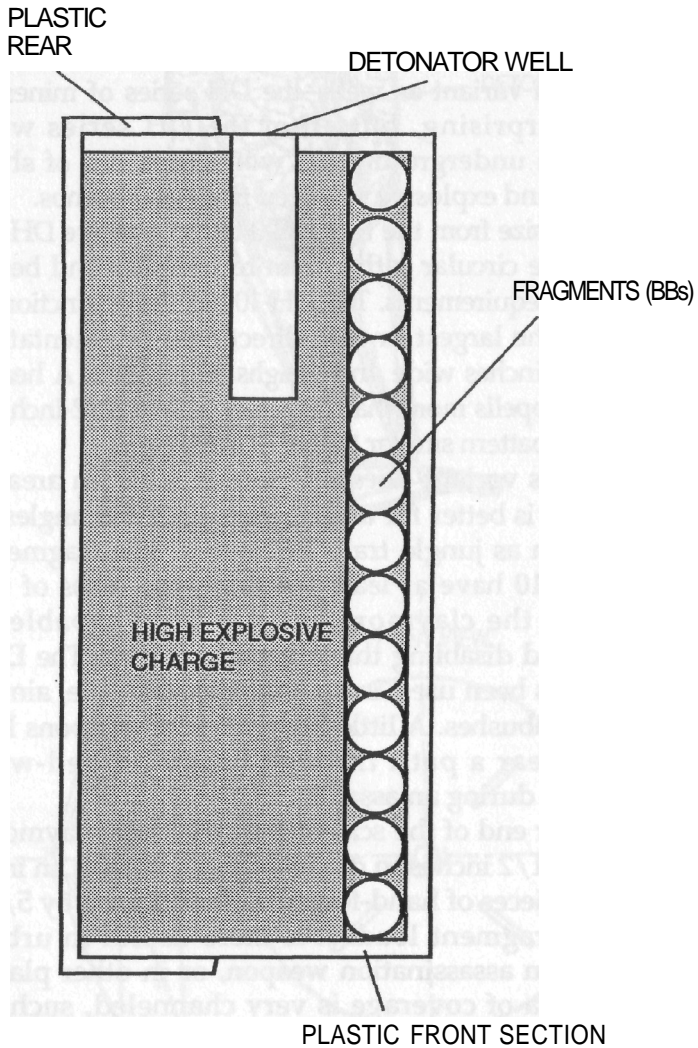

VIETCONG DIRECTIONAL MINES

The Vietcong were so impressed by the performance of the M-18A1 claymore that they had an almost identical copy, the MDH, produced in North Vietnam for their own use. Meanwhile, back in their jungle ordnance factories, they built their own variant as well—the DH series of mines. It may seem surprising, but all of the DH series were constructed in underground VC workshops out of sheet metal, scraps, and explosive salvaged from dud bombs.

Ranging in size from the tiny DH-3 to the massive DH-10, these mines are circular rather than rectangular and better suited to their requirements. The DH-10 has the distinction of being one of the largest known directional fragmentation mines. It is 18 inches wide and weighs 20 pounds. A heavy TNT charge propells more than 450 steel pellets (1/2-inch) in a cone-shaped pattern similar to that of a shotgun.

Though this variant doesn't cover as wide an area as the M-18A1, it is better for aiming down narrow angles of approach, such as jungle trails or ravines. The fragments from the DH-10 have at least ten times the mass of the ones used in the claymore and are fully capable of penetrating and disabling thin-skinned vehicles. The DH-10 can and has been used in an antihelicopter role, aimed upward for ambushes. A little-known use of weapons like these is to clear a path through heavy barbed-wire entanglements during an assault.

At the other end of the scale is the DH-3 miniclaymore. This mine is 2 1/2 inches in diameter and less than an inch thick. It uses pieces of hand-forged nails, 1/8 inch by 5/16 inch, for its fragment load. It is more useful in urban situations as an assassination weapon, or in other places where the area of coverage is very channeled, such as alleys or the narrow streets common to some areas of Southeast Asia.

THEIR EMPLOYMENT AND DESTRUCTIVE CAPABILITIES

VIETCONG DH-10 DIRECTIONAL MINE

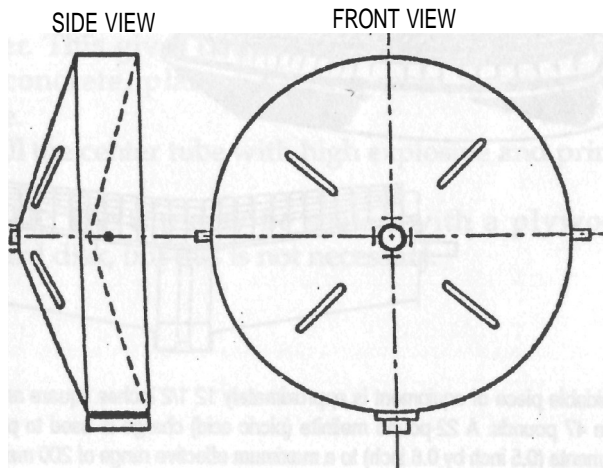
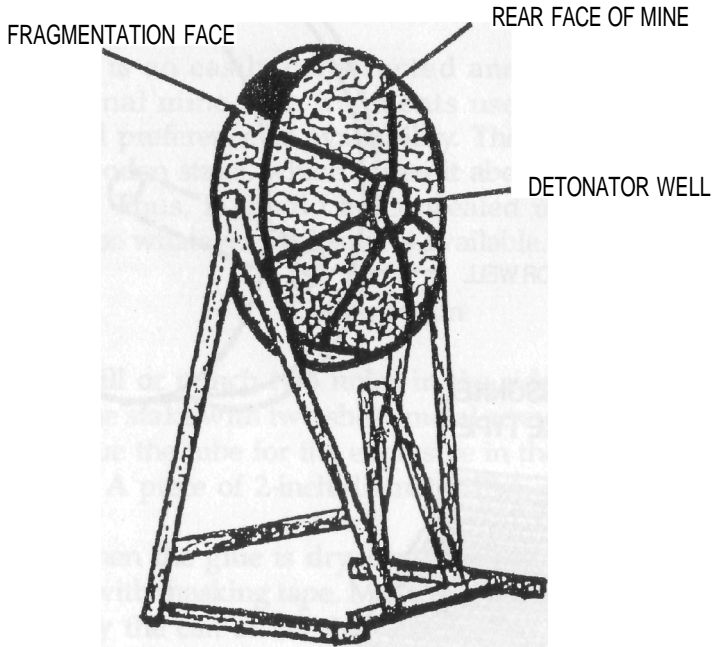

IMPROVISED LAND MINES

DH-3 MINICLAYMORE

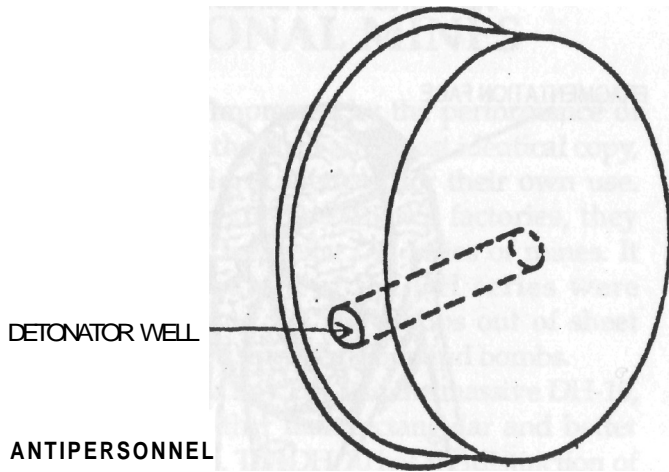

FRENCH ANTIPERSONNEL MINE, CLAYMORE TYPE

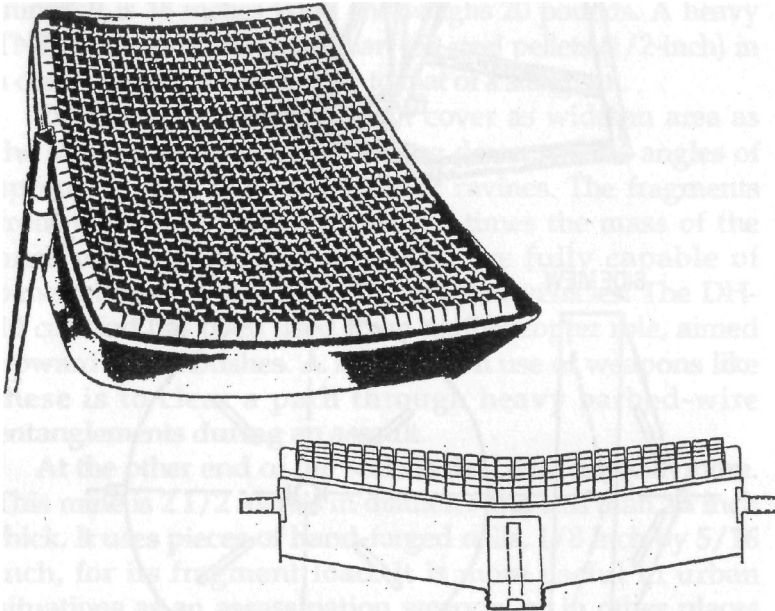

This formidable piece of equipment is approximately 12 1/2 inches square and weighs more than 47 pounds. A 22-pound melinite (picric acid) charge is used to propel 530 steel fragments (0.5 inch by 0.6 inch) to a maximum effective range of 200 meters.

COFFEE-CAN CLAYMORE

This is an easily constructed and highly effective directional mine. The fragments used are a matter of personal preference or availability. The mine is mounted on a wooden stake, which raises it about one foot off the ground. Thus, it should be concealed in a bush or tall grass. Use whatever explosive is available.

Construction

1. Drill or punch two holes in the side of the can and attach the stake with two sheet-metal screws.

2. Glue the tube for the explosive in the exact center of the can. A piece of 2-inch-diameter PVC pipe with cap is suitable.

3. When the glue is dry, cover half of the open top of the can with masking tape. Make a good, thick layer.

4. Lay the can on its side and fill the taped side with concrete, plaster, or casting resin. Allow to dry.

5. Fill the open side with metal fragments. A binder should be used to coat the fragments and hold them together. This gives better range and a tighter pattern. Weak concrete, plaster, casting resin, or even wax is suitable.

6. Fill the center tube with high explosive and prime.

NOTE: The top may be sealed with a plywood or cardboard disk, but this is not necessary.

COFFEE CAN CUYMORE

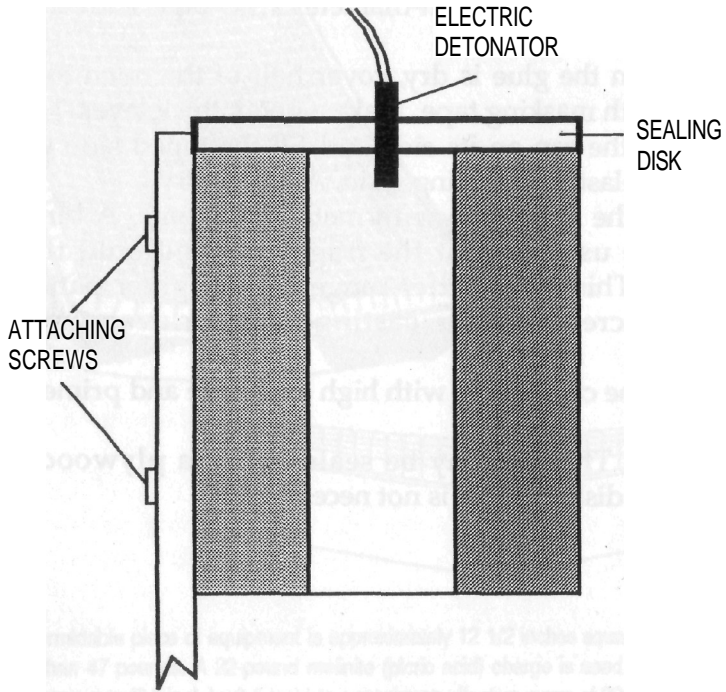
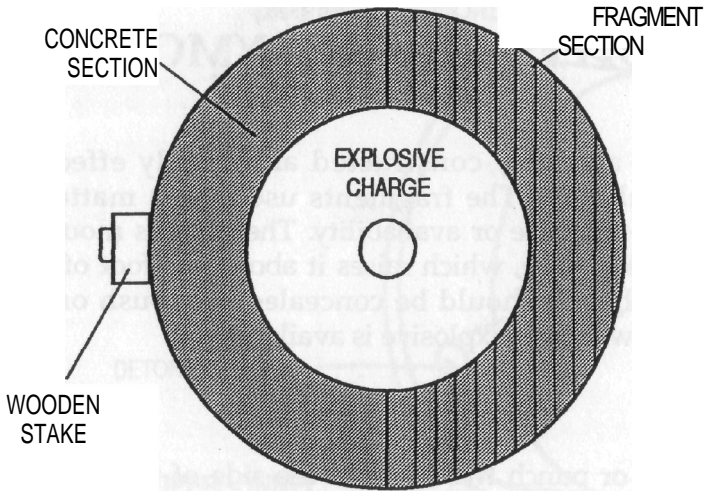

ANTITANK MINES

As previously mentioned, AT mines are larger than AP mines. The most common targets for guerrilla AT mines are autos (command and recon), trucks (supply and personnel), and armored personnel carriers (APCs). Cars and trucks are usually destroyed by a typical AT mine, while APCs are at least flipped over.

Guerrillas rarely encounter tanks, except when they ambush armies in transit. Tanks are seldom used in antiguerrilla operations because it is difficult to sneak up on someone in one of the noisy buggers. The main danger from tanks to guerrillas is their accompanying infantry support. Should an adversary be stupid enough to pursue with tanks, the wisest course of action is to fade away. If the tanks' route can be determined, some high-explosive surprises can be planted for them and the accompanying infantry.

Special care must be taken with the laying of mines if there is significant civilian traffic in the area of operation. If the populace consists mostly of sympathizers, civilian contacts should be apprised of the mine pattern or sentries can escort noncombatant vehicles through the mined area. If the locals are not sympathizers, it may be best to use command-detonated mines. The bad press and general hostility generated from killing locals (known in Vietnam as FUF, fucking up friendlies) are not to be taken lightly. Laying mines as needed for specific ambushes, rather than indiscriminate mining, is generally better.

The most common AT mine is the blast type, which usually contains from 12 to 30 pounds of high explosive. It is designed to immobilize tanks by breaking or damaging their tracks. But merely immobilizing tanks leaves what amounts to a heavily armored pillbox full of irate tankers inside. Guerrillas generally attempt to get the tankers to surrender since the average tank contains enough explosive shells, machine guns, and fuel to gladden the

hearts of any guerrilla band. If possible, snap off the radio antennae to prevent their calling for help. If the tankers become a problem, they can be dealt with by tossing a satchel charge under the rear overhang of the turret or dousing the engine compartment with about 10 gallons of flaming gasoline.

Killer mines are the tank destroyers and generally use either a shaped charge (see that section, page 61, for details) or plate charge (Misnay-Chardin). The plate charge is similar, but not identical, to the platter charge. The platter charge, an old Special Forces favorite, uses a platter of steel or glass to penetrate thin metal targets from a distance. The standard formula is to use equal weights of explosive and platter. The actual damage is done by a highly compacted and superheated mass of air in front of the platter.

Plate charges operate on a slightly different principle, the explosively formed projectile (EFP). They use a larger explosive charge—often three times the weight of the plate—and generally copper or mild steel as the projectile material. The force of the explosion transforms the thick metal disk into a powerful blunt-nosed projectile that easily penetrates the belly armor of a tank. The EFP then bounces around the tank's interior, much to the detriment of its occupants and contents.

This type of charge has also been used as a horizontal-penetration mine by many countries, and at least one variant is capable of penetrating four inches of armor plate at a range of 70 meters with good accuracy. The production of this type of mine is quite complex and outside the range of this book, but if you would like more details, the April 1987 issue of *Military Technology* (*MILTECH*) magazine has an excellent article on the design of EFP charges.

THEIR EMPLOYMENT AND DESTRUCTIVE CAPABILITIES

PLATE-CHARGE ANTITANK MINE

| Mine Model | Vertical or Horizontal | weight of Mine | Weight of Platter | Weight of Explosive | Type of Explosive |
|-------------------|-------------------------------|-----------------------|--------------------------|----------------------------|--------------------------|
| SMI 22/7C | H | 13.5 kg | ? | 7 kg. | Comp. B |
| ATM-7 | H | 14 kg. | 2.8 kg. | 9 kg. | Comp. B |
| SB-MV/T | V | 5 kg. | ? | 2.6 kg. | Comp. B |
| FFV028 | V | 7.9 kg. | ? | 3.8 kg. | Cyclotol |
| M-21 | V | 7.9 kg. | ? | 4.9 kg. | H6 |

NUMBER 75 HAWKINS GRENADE MINE

The Hawkins grenade, as it was more familiarity known to British troops, is a light antitank mine based on a flat, 1-pint can. It contains about 1.74 pounds of a commercial explosive, such as Burrowite, and a booster charge. The U.S. M-7A2 is based on a 1-quart can, filled with Tetrytol. Mines such as these are excellent for long-term use.

To use, cut a hole in the side of the can and seal a metal-lined fuze securely in place. Loading the explosive could be a problem because of the small-diameter spout, but a good solution is to use liquid explosive or, in fact, nitroglycerin converted into blasting gelatin in the can. Fill the can to the proper level (never full) with nitroglycerin, add the chalk and nitrocellulose (see *The Anarchist Arsenal: Improvised Incendiary and Explosives Techniques*), stir well, and place in a warm-water bath to gel. Using commercial dynamite eliminates the hazards of nitro leaking, but stuffing shredded explosive through a narrow neck and trying to tamp it into place is tedious. Cast explosives, such as TNT, are also tedious to tamp into place, but they can be used if necessary.

NUMBER 75 HAWKINS GRENADE MINE

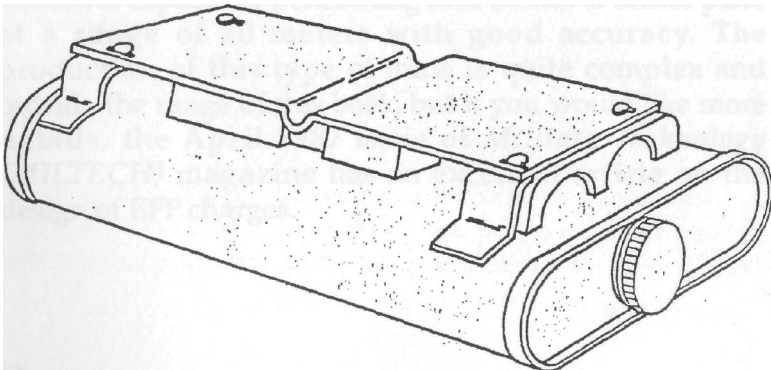

IMPROVISED ARTILLERY-SHELL MINE

This is an excellent example of how to use unexploded (dud) ordnance properly. After removing the arming devices, install a standard MUV-type pull fuze. When pressure is applied to the pressure board, it pivots and

IMPROVISED ARTILLERY-SHELL MINE

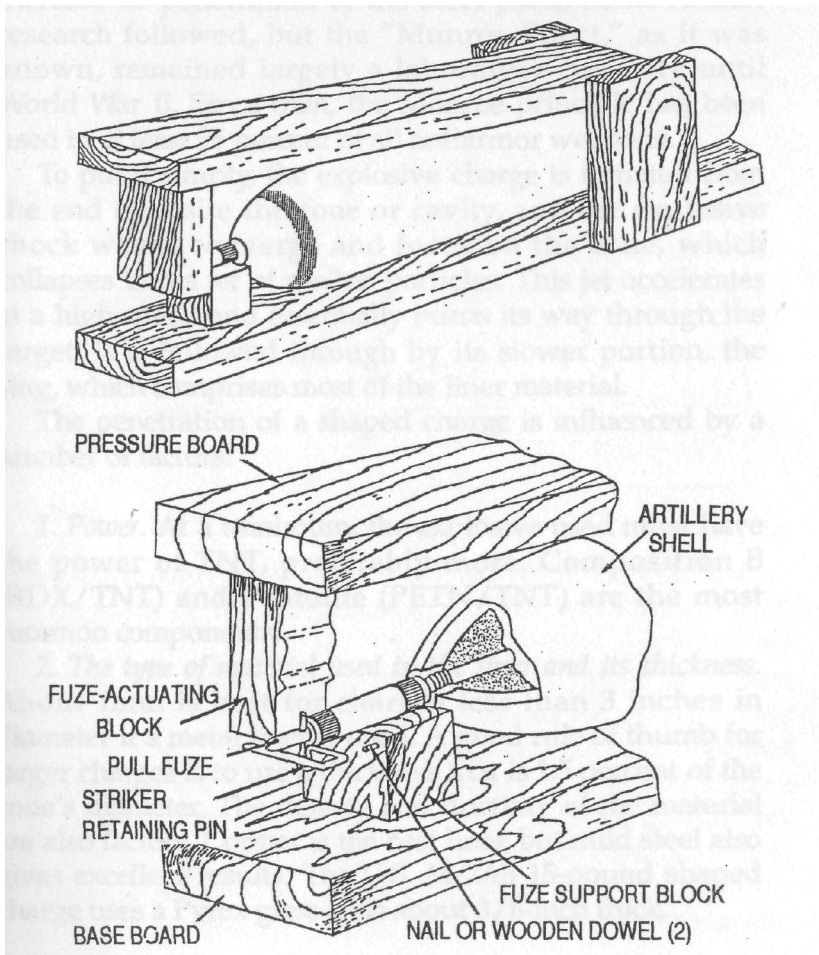

IMPROVISED LAND MINES

displaces the safety pin from the fuze. The pressure board must be supported by two nails or dowels, otherwise its weight alone would be sufficient to cause the fuze to function. It is easily built from scrap lumber and, depending on the size of the artillery shell used, is effective against personnel or vehicles. Depending on the weather and soil conditions, it may be desirable to cover it with a layer of plastic sheeting before it is covered with dirt.

SHAPED-CHARGE PRINCIPLES

The principle of the shaped or cavity charge was discovered in the late nineteenth century by U.S. Naval scientist C.E. Munroe. He found that when a block of explosive that had letters countersunk into its surface was detonated against a steel plate, the letters were indented into the plate's surface. Through experimentation he found that by increasing the depth of the cavity he could increase its penetration of the steel plate. Some further research followed, but the "Munroe Effect," as it was known, remained largely a laboratory curiosity until World War II. Since then, the Monroe principle has been used in at least 95 percent of all antiarmor weapons.

To put it simply, the explosive charge is initiated from the end opposite the cone or cavity, and the explosive shock waves converge and focus on the cone, which collapses into a jet of molten particles. This jet accelerates at a high speed and essentially burns its way through the target. It is followed through by its slower portion, the slug, which comprises most of the liner material.

The penetration of a shaped charge is influenced by a number of factors:

1. *Power.* At a minimum, the explosive used must have the power of TNT, preferably more. Composition B (RDX/TNT) and Pentolite (PETN/TNT) are the most common components.

2. *The type of material used in the liner and its thickness.* About 1mm is best for charges less than 3 inches in diameter if a metal liner is used. A good rule of thumb for larger charges is to use a thickness that is 15 percent of the cone's diameter. The density and ductility of the material are also factors. Copper is the best liner, but mild steel also gives excellent results. The U.S. M-2A3 15-pound shaped charge uses a Pyrex glass cone about 3/8-inch thick.

SHAPED-CHARGE PRINCIPLES

BASIC SHAPED CHARGE

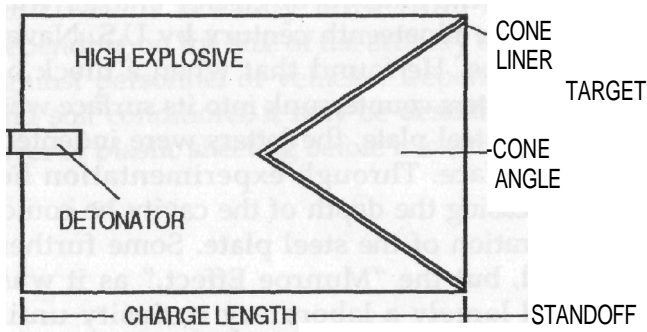

SHAPED CHARGE WITH WAVE SHAPER

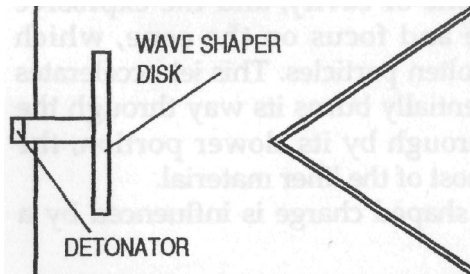

3. *The angle of the cavity.* It should be from 30 to 60 degrees. Most antitank weapons use a 42- to 45-degree cone angle.

4. *The shape of the cavity.* Cones with the above specifications produce the deepest penetration, but hemispherical liners produce wider holes.

5. *Standoff.* This is the distance between the target and the base of the cone, and it is needed to allow the jet to reach maximum penetration velocity. A good rule of thumb is to use a standoff equal to 1 1/2 times the diameter of the charge.

THEIR EMPLOYMENT AND DESTRUCTIVE CAPABILITIES

6. *The height of the explosive charge.* It should be 2 times the cone or liner height. A relatively recent development in the field is the "wave shaper." Most modern AT weapons incorporate a wave-shaper disk into their design. This disk can be made of several different materials, but lead works best.

The wave shaper can enhance the penetration of the charge as much as fourfold. Weapons experts believe it accomplishes this in two ways. First, since the explosion is initiated above the disk, it presses down on the main explosive charge, compressing it to a higher density and, hence, a higher velocity. Second, it initiates the detonation of the main explosive charge from all sides (a technique known as peripheral detonation) and thus increases its speed. A similar technique is used in some current-production nuclear weapons. A wave shaper is a good idea if the charge is to be used as a horizontal-penetration mine.

Effect of Liner Material on Shaped-Charge Efficiency (3-inch charge, 1mm liner thickness)

| Liner Material | Density | Depth at Optimum Standoff (inches) | Diameter of Entrance Hole (mm) |
|-----------------------|----------------|---|---------------------------------------|
| Copper | 8.8 | 7.5 | 18 |
| Steel | 7.8 | 5.0 | 16 |
| Zinc | 7.2 | 4.5 | 22 |
| Aluminum | 2.7 | 5.0 | 23 |

As you can see from the chart above, copper is the best liner if depth of penetration is the primary goal, as in the case of horizontal-penetration mines. Aluminum gives only about two-thirds as much penetration but produces a hole about 22 percent wider, making it superior for vertical-penetration mines. Because a tank's belly armor is rarely more than 2 inches thick and can be penetrated by a crude "wine bottle" shaped charge, aluminum is suitable

IMPROVISED LAND MINES

for this use. However, the charge does not retain much residual power to damage the target's interior. Of course, aluminum is much cheaper than copper.

WEST GERMAN AT WARHEAD USING WAVE SHAPER

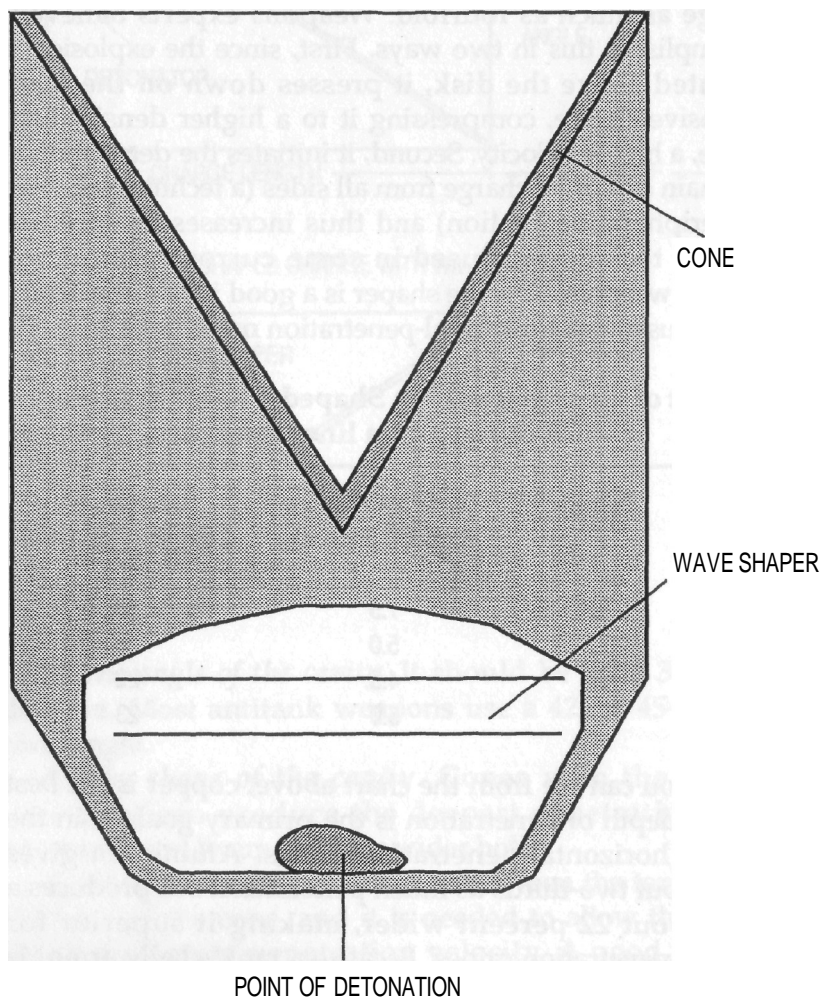

VERTICAL- PENETRATION MINES

Vertical penetration (VP) killer mines use a shaped or plate charge to penetrate the thin belly armor of a tank and destroy its contents. Generally, a large shaped charge is preferable, not for the depth of penetration it provides but for the residual power the jet retains. This ensures the maximum damage to the personnel, power train, and ammunition components of the vehicle.

TRIP-WIRE EMPLACEMENT OF VERTICAL-PENETRATION MINE

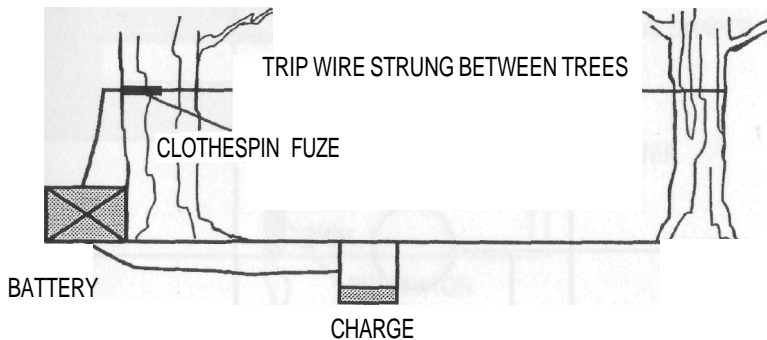

DETAILS OF CLOTHESPIN FUZE

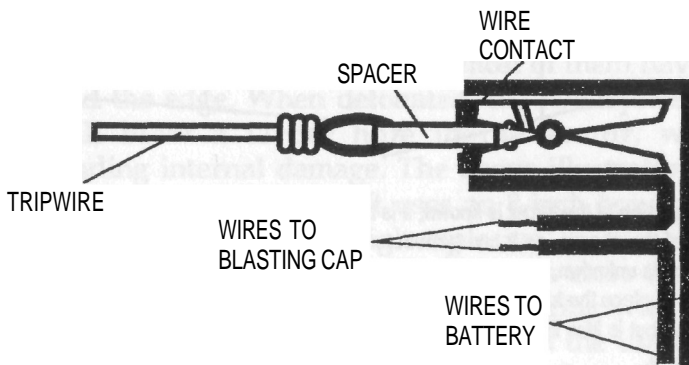

IMPROVISED LAND MINES

Since depth of penetration is a secondary consideration in this case, a hemispherical liner is better. Steel or aluminum mixing bowls are cheap and readily available, whereas copper or even steel cones in the right shape and size can be expensive.

Nest two of the bowls together to form the liner since they are usually rather thin. They are also easier to

TRIP-WIRE FUZE EMPLACEMENT OF VERTICAL-PENETRATION MINE

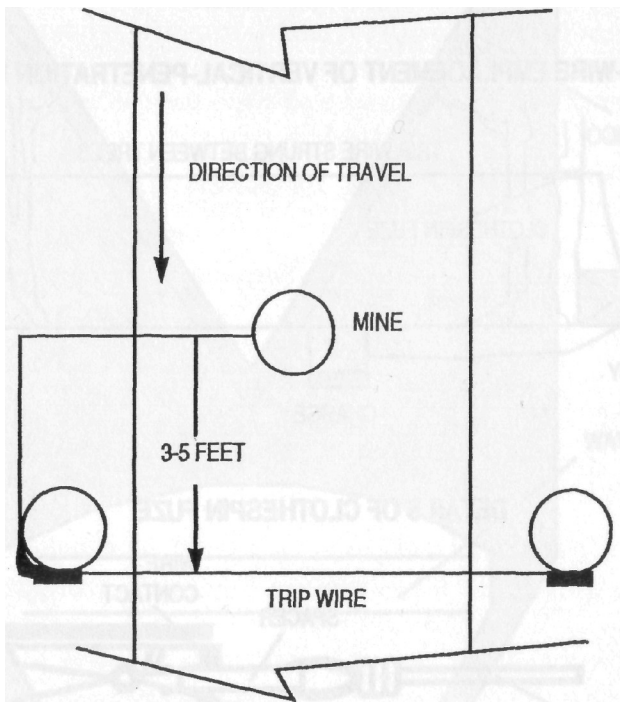

If the direction of the target is known, it is best to offset the mine fuze about 3 to 5 feet ahead of the charge, so it can penetrate a more vulnerable area. If the direction of approach is unknown, place the fuze in line with the mine. A good trick with this type of setup is to place the trip wire high in the trees, where it will be caught by the tanks' long antennae but is less likely to be observed. In this case, the charge should be centered on the wire.

THEIR EMPLOYMENT AND DESTRUCTIVE CAPABILITIES

HEMISPHERICAL-SHAPED CHARGE USED IN VERTICAL-PENETRATION MINE

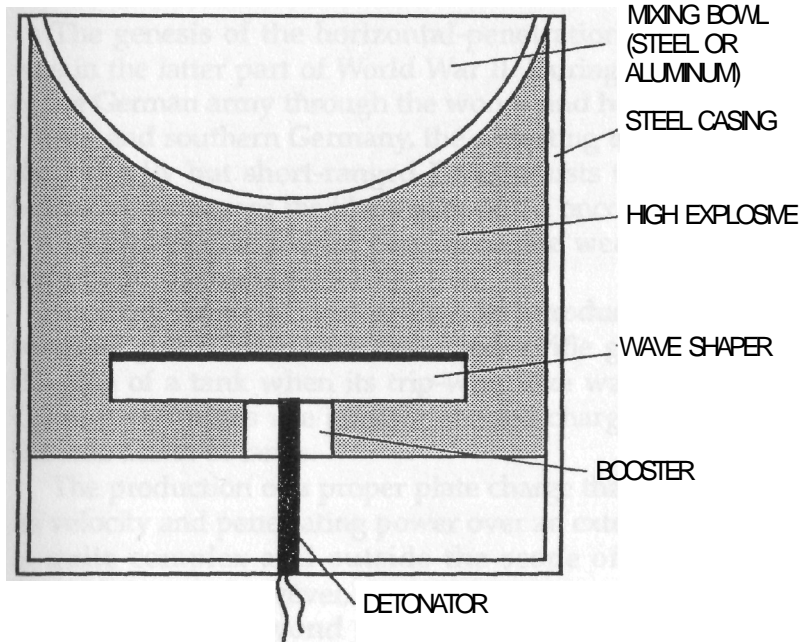

The hemispherical liner produces shallower, wider holes, which are ideal for this application because they blow big holes through comparatively thin armor. The heavy steel casing improves the penetration of the charge, but it is optional.

assemble into charge containers since most of them have a lip around the edge. When detonated, the hemispherical liner will blow a larger hole in the armor, with corresponding internal damage. The above illustration is an example of such a charge. It uses an 8-inch bowl and holds about 8 to 10 pounds of high explosive.

The mines are buried in the road bed, as close to the surface as possible to avoid anything interfering with the formation of the jet. A recent trend has been the use of a low-explosive "cover charge" to blow away the covering

IMPROVISED LAND MINES

dirt a fraction of a second before the shaped charge detonates. A VP mine is usually command-detonated, but trip wires can also be used.

HORIZONTAL- PENETRATION MINES

The genesis of the horizontal-penetration (HP) mine was in the latter part of World War II. During the pursuit of the German army through the woods and hedgerows of France and southern Germany, the retreating troops wired their deadly but short-ranged Panzerfausts to trees and fences, aimed across the likely path of the oncoming tanks. An improvised trip-wire fuze fired the weapon at the appropriate moment.¹

At about the same time the Soviets introduced the light machine gun (LMG) mine that fired a rifle grenade into the side of a tank when its trip-wire fuze was activated. Current HP mines use plate or shaped charges to attack the side armor of tanks.

The production of a proper plate charge that will retain its velocity and penetrating power over an extended range is quite complex and outside the scope of this book. Shaped charges, however, retain their penetration velocity at distances far beyond their normal standoff. This is particularly true of charges with metal liners. The depth of penetration achieved depends entirely on the length of the standoff. For example, a U.S. 40-pound shaped charge may be placed up to 14 feet away from the target and still penetrate up to 4 inches of armor. The 40-pound charge uses a 10-inch-diameter mild-steel cone with a 60-degree angle. Backed by 30 pounds of Pentolite or composition B, it will blow a 5-inch hole through 20 inches of armor plate, with its normal 15-inch standoff. The charges may be lashed to trees, hedges, or dug into embankments, preferably within 6 to 10 feet of the roadway. A set of sturdy steel legs may be mounted on the mine to act as a support, much in the same manner as the tripod on a camera or machine gun. If you have the choice, always place the charges to fire into the tank's right side. This is

where the fuel and ammunition are stored on most Soviet model tanks, and a good hit will ensure their destruction. The thickness of a tank's armor is not equal on all sides. The armor on the front hull and turret is thickest because these are the most exposed areas during an attack. The next thickest armor is on the sides, rear, top, and belly, in that order. Always go for the thinnest armor. In most cases, the belly and sides are the prime targets, but sometimes it is possible and advisable to attack through the top armor. Large shaped charges have been hung in tree limbs and city archways, aiming down, and command-detonated at the appropriate time.

HISTORICAL NOTE: British forces encountered a unique command-detonated AT mine during their drive through Burma in late 1944. Japanese soldiers were crouched in camouflaged foxholes, cradling an artillery projectile or small aircraft bomb between their knees. When a tank or other worthy target passed over their hole, they would smack the bomb fuze with a small metal bar, detonating it. Any volunteers?

¹ More recently, the Vietcong used a similar setup to fire RPG-2 and RPG-7 rockets from ambush. The VC fired rockets from lengths of bamboo that were fitted with trip wires or command-triggering mechanisms.

THEIR EMPLOYMENT AND DESTRUCTIVE CAPABILITIES

HORIZONTAL-PENETRATION MINE

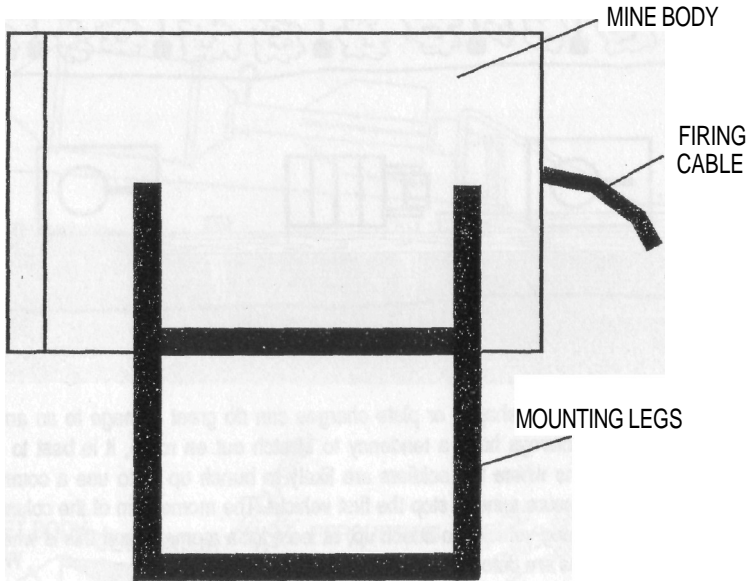

SIDE VIEW

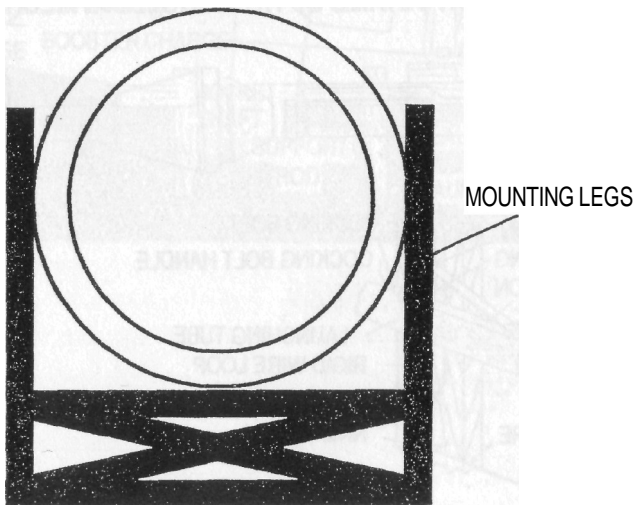

FRONT VIEW

IMPROVISED LAND MINES

FIRING MAIN LINE

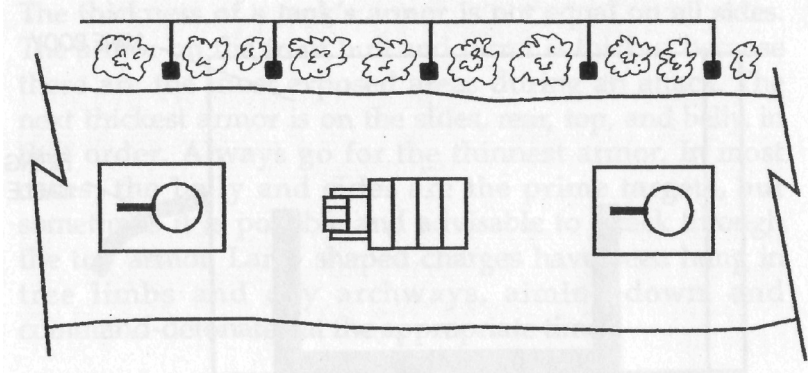

A series of horizontal shaped or plate charges can do great damage to an armored column. Since convoys have a tendency to stretch out en route, it is best to place mines in locations where the soldiers are likely to bunch up or to use a command-detonated or pressure mine to stop the first vehicle. The momentum of the column will cause the remaining vehicles to bunch up, at least for a moment, and this is when the rest of the charges are detonated simultaneously.

PANZERFAUST WITH DETAILS OF ITS TRIGGERING MECHANISM

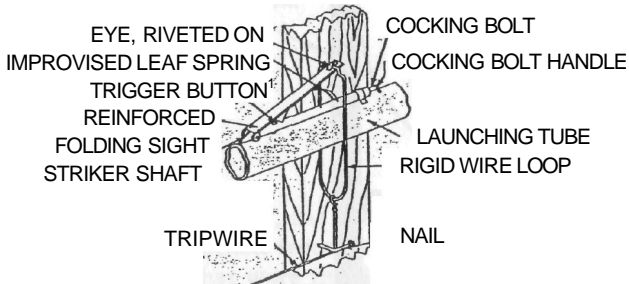
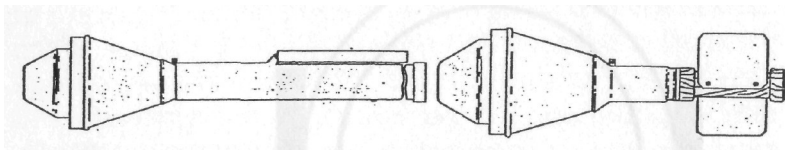

THEIR EMPLOYMENT AND DESTRUCTIVE CAPABILITIES

**LMG ANTITANK MINE
(GAUTSKI FLYING MINE)**

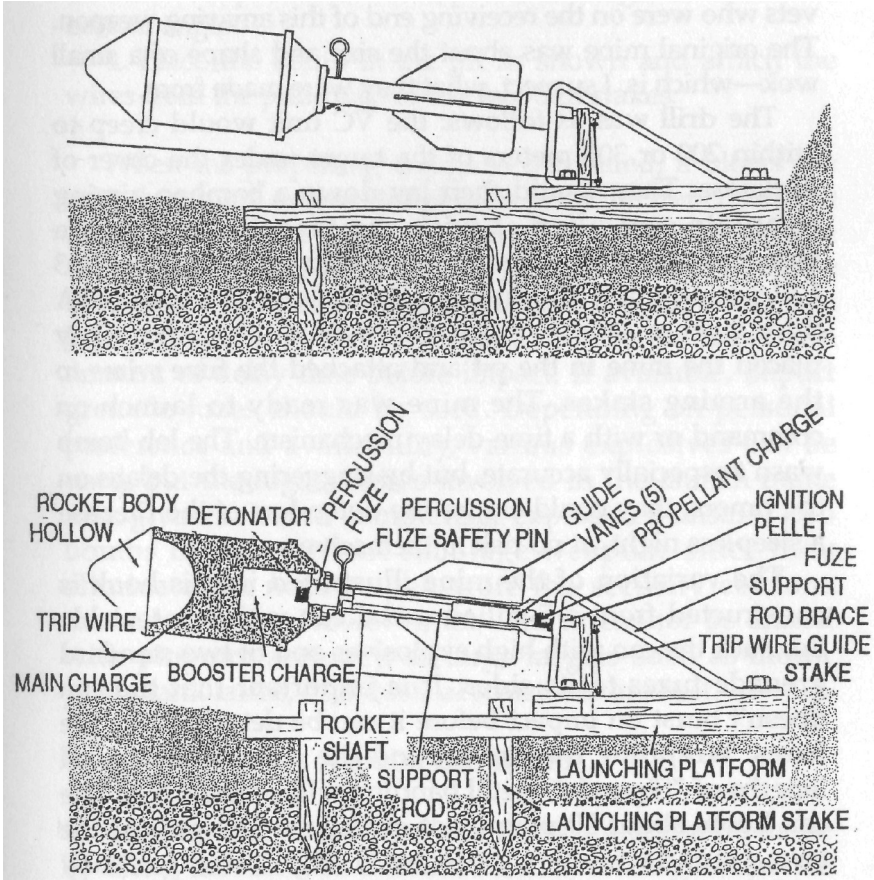

FLYING MINE

The flying mine or "lob bomb" is familiar to Vietnam vets who were on the receiving end of this amazing weapon. The original mine was about the size and shape of a small wok—which is, I suspect, what they were made from.

The drill was as follows: the VC unit would creep to within 200 or 300 meters of the target under the cover of darkness. They would then lay down a bamboo aiming template and align it with the target. They dug a launching pit and placed the propelling charge (usually 3 1/2 pounds of TNT) in a special hole in the bottom. A thick layer of sand or loose soil covered the charge. They placed the mine in the pit and attached the fuze wires to the arming stakes. The mine was ready to launch on command or with a time-delay mechanism. The lob bomb wasn't especially accurate, but by staggering the delays on the timers, they could assure the defenders of the firebase a sleepless night, at no risk to themselves.

The variation of the mine illustrated in this book is constructed from a 5-gallon metal can with a resealable lid. Pack the can with high explosives and fit two standard grenade fuzes to its sides. It is important that the can doesn't burst on impact before it can be detonated by the fuzes. Wrapping the can around the ends with several lengths of "Signode" metal banding will prevent this. The can holds about 50 pounds of explosive. The pins of the two grenade fuzes should be straightened for easy withdrawal, and the grenades should be turned so the pins face the rear of the bomb. Testing must be done to determine the range, angle needed, and propulsive charge.

To Install

1. Dig an angled pit (as shown on page 76), using the aiming stakes to achieve proper direction.

THEIR EMPLOYMENT AND DESTRUCTIVE CAPABILITIES

2. Place the propelling charge in its hole and cover with at least 2 cubic feet of dirt.

3. Put the pusher board in place, making sure it is at the correct angle.

4. Place the bomb in the pit as shown and attach the wires from the pull rings to the wooden stakes.

When the propelling charge is detonated, it blows the mine in a more or less straight line with the trench. As the mine launches, the wires attached to the pull rings activate the grenade fuzes, giving 4 1/2 to 5 seconds before detonation. For this reason, it is best to lob the bomb in a high arc, similar to that of a mortar, to use the maximum amount of delay time before impact. If available, impact grenade fuzes should be used. Depending on personal preference and availability, various explosives can be used, but the high stresses involved in the launch make nitroglycerin-based commercial explosives unsafe. Lob bombs make excellent sabotage weapons since they eliminate the need to penetrate the security cordons around a target. However, lob bombs cannot be aimed with pinpoint accuracy, so large targets such as motor pools, tank farms, or industrial structures are best.

Napalm Lob Bomb

An incendiary version of the flying mine can be made by filling the can with thickened fuel and using two white phosphorus (WP) grenades as the fuzes. Be sure that the can is well-sealed to prevent leakage and that it is strong enough to survive the shock of launching. This mine doesn't need to be as heavy as the high-explosive version. If it bursts on impact, as it likely will, the WP grenades have an adequate bursting radius (generally about 25 meters) to ensure that the fuel will light.

IMPROVED LAND MINES

LOB BOMB EMPUCEMENT

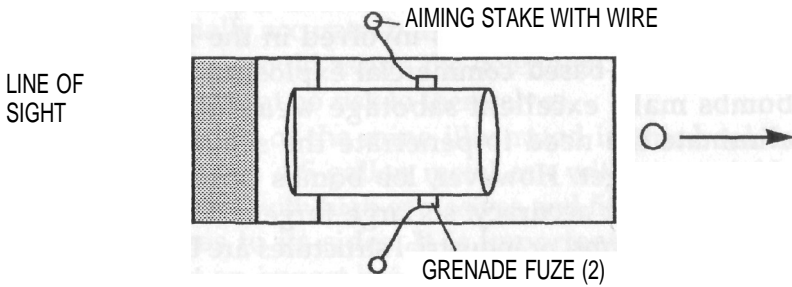
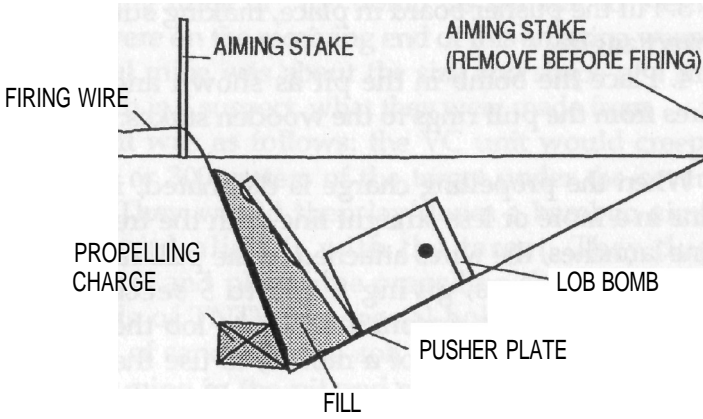

THEIR EMPLOYMENT AND DESTRUCTIVE CAPABILITIES

HIGH-EXPLOSIVE LOB BOMB

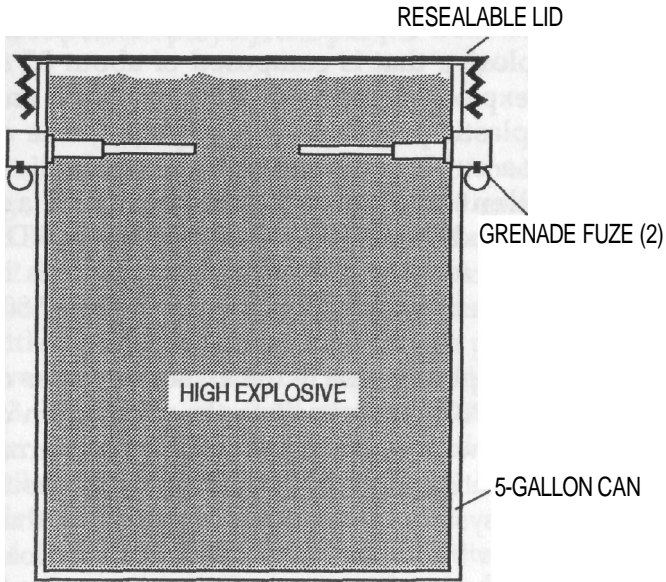

NAPALM LOB BOMB

RESEALABLE LID

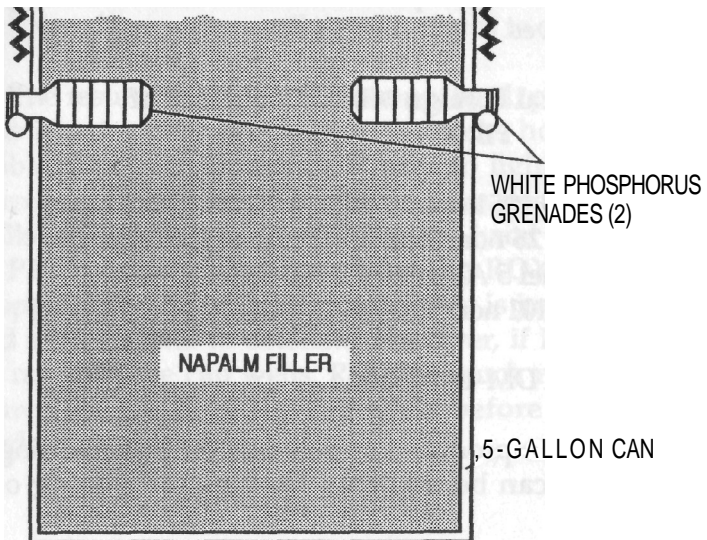

PLASTIC BONDED EXPLOSIVES

The plastic bonded explosive (PBX) is a relatively new class of explosive that is composed of about 85 to 95 percent high explosive (generally RDX or PETN) and 5 to 15 percent plastic polymer, such as polystyrene or polyester. These explosives have high mechanical strength, excellent explosive properties, and are extremely stable and insensitive to shock. Since RDX and PETN are the most-common base explosives in PBXs, the average detonation velocity is more than 7,800 meters per second.

Originally developed for use in the explosive lenses of nuclear warheads, PBX lends itself to the production of land mines because with it the mines require no external casing. Thus, the entire mine body and, in some cases, parts of the fuzing system can be made of explosive, thus increasing its power by improving its weight-to-payload ratio. An added bonus is that PBX reduces the mine's metal content, making it harder to detect. These explosives have proven to be more than strong enough to handle the normal bumps and shocks that the average land mine receives.

Typical Foreign Mines Composed of PBX-Type Explosives

- French Model 1951 nonmetallic AT mine (TNT base)
- Dutch Model 26 nonmetallic AT mine (TNT base)
- Swedish Model 5 AT mine (50/50 cydotol base)
- Swedish M-1-101 nonmetallic AT mine (TNT or cydotol base)
- West German DM-11 AT mine

Most PBXs are produced as powders for press loading, but they also can be made as slurries for casting or

THEIR EMPLOYMENT AND DESTRUCTIVE CAPABILITIES

injection molding. Following are directions for a simplified version of PBX-1, composed of 90 percent RDX and 10 percent polystyrene plastic.

Construction

1. Weigh the required amount of polystyrene foam (e.g., 100 grams of PBX consist of 10 grams polystyrene and 90 grams RDX) and place it in the mixing vessel.

2. Splash a little acetone over the foam and allow it to dissolve (this does not take long). When it has melted, add a little more acetone if necessary so the plastic has a layer of solvent over its surface that is about 1/4- to 1/2-inch thick.

3. Weigh the required amount of sifted RDX crystals. Pour these into the mixing vessel and stir with a spatula until a smooth, even, lump-free mix is obtained. Add a little more acetone if necessary.

4. Heat the mixing vessel in a hot-water bath to evaporate the excess solvent. Be sure you have adequate ventilation because acetone and its fumes are flammable and can be explosive. When the consistency of the mixture resembles that of thick oatmeal, the PBX may be pressed into molds and placed in a warm, well-ventilated area to cure.

The resulting product is a strong, hard, plastic material that is extremely shock-resistant. It is, however, flammable, and even though it is hard to light, it will burn fiercely once lit. Just keep it away from open flames. Cap wells can be bored into the PBX with a hand drill.

PETN can be substituted for the RDX in the same proportions, yielding an explosive that is just as powerful and a little easier to detonate. However, if PETN is used, do not drill the cap wells. PETN is much more sensitive than RDX, so form the cap wells before the material hardens completely.

WEST GERMAN DM-11 ANTTANK MINE

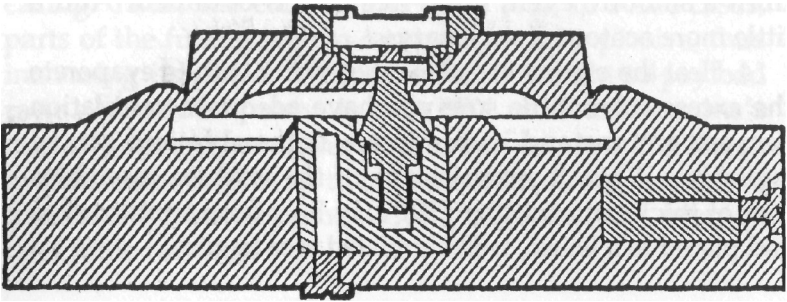
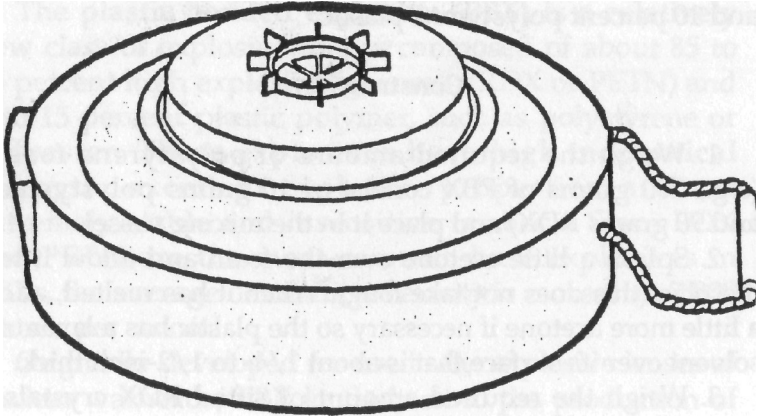

The West German DM-11 AT mine is composed almost entirely of high explosive. A mixture of cast TNT and polyester resin (5 percent) provides the required strength. As you can see, even the pressure plate and parts of the fuze are made of explosive.