

Homemade Break-barrel Shotgun

Construction plans

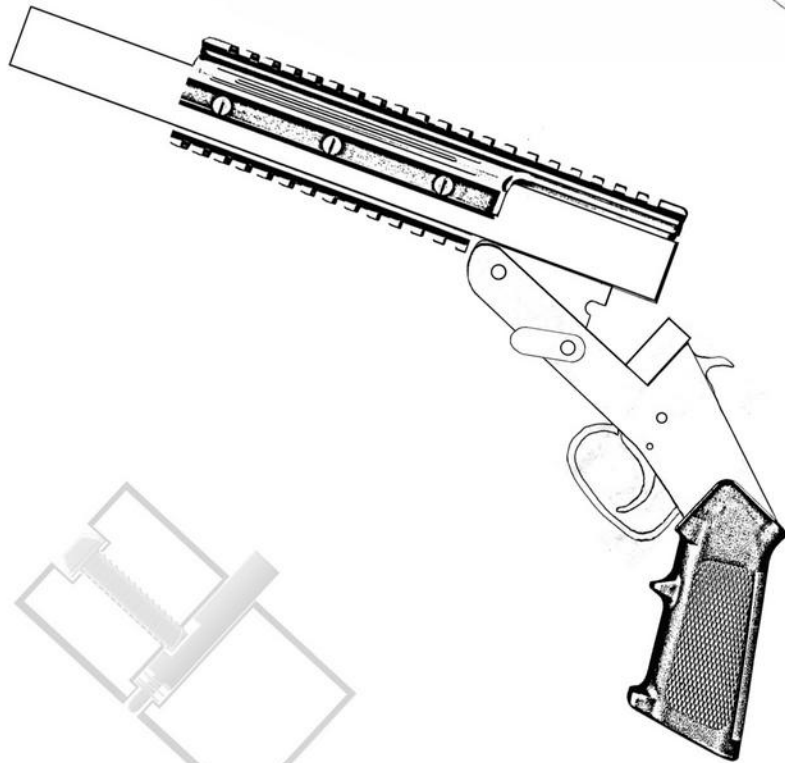

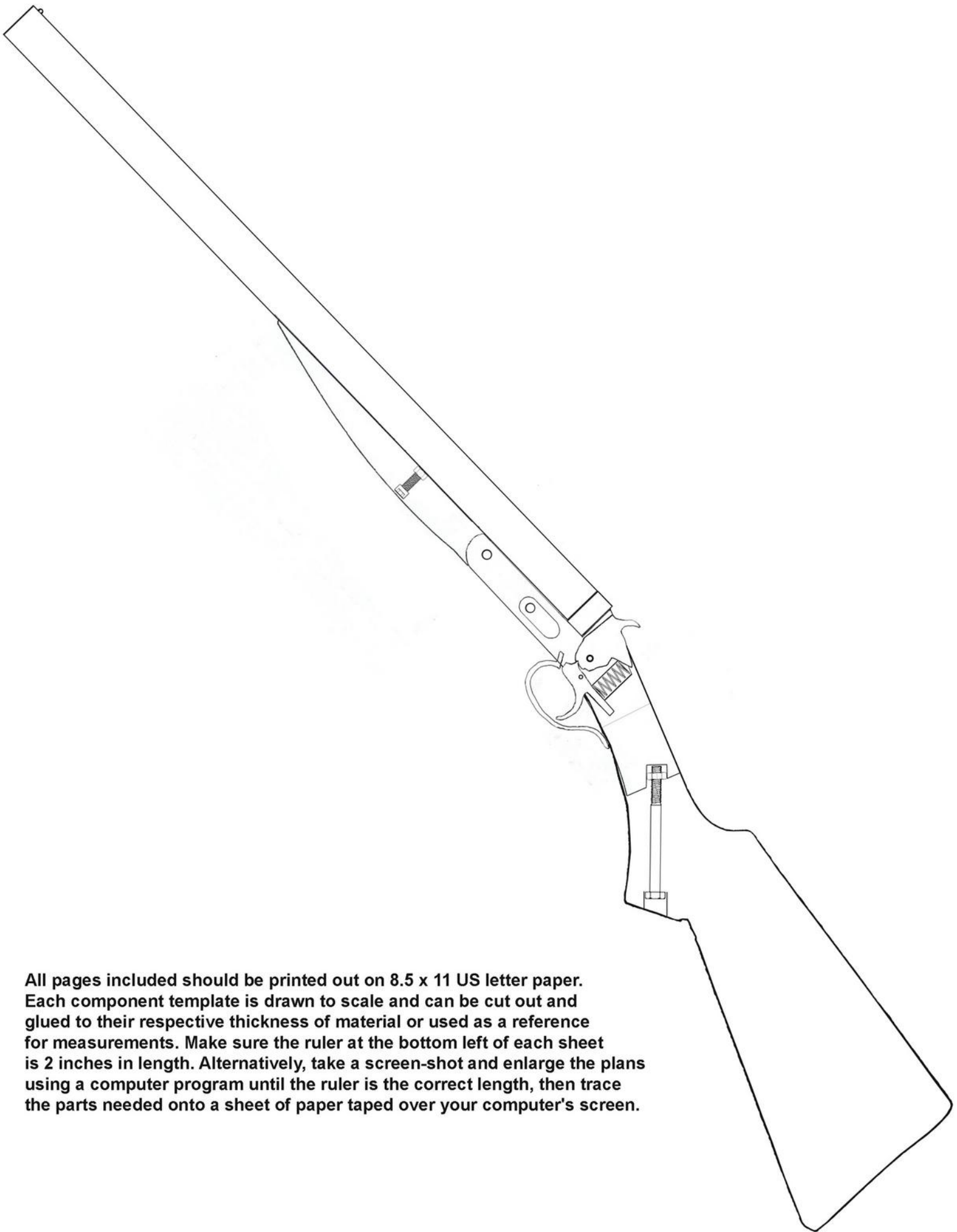

All pages included should be printed out on 8.5 x 11 US letter paper. Each component template is drawn to scale and can be cut out and glued to their respective thickness of material or used as a reference for measurements. Make sure the ruler at the bottom left of each sheet is 2 inches in length. Alternatively, take a screen-shot and enlarge the plans using a computer program until the ruler is the correct length, then trace the parts needed onto a sheet of paper taped over your computer's screen.

Frame & trigger group templates

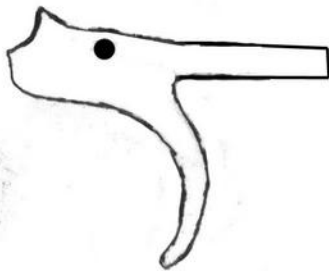
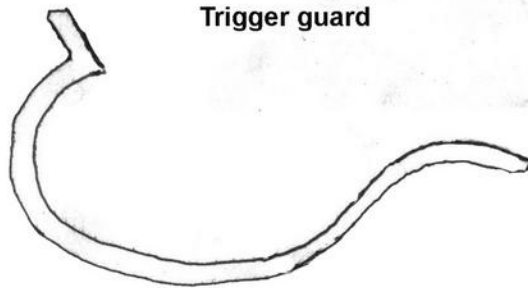
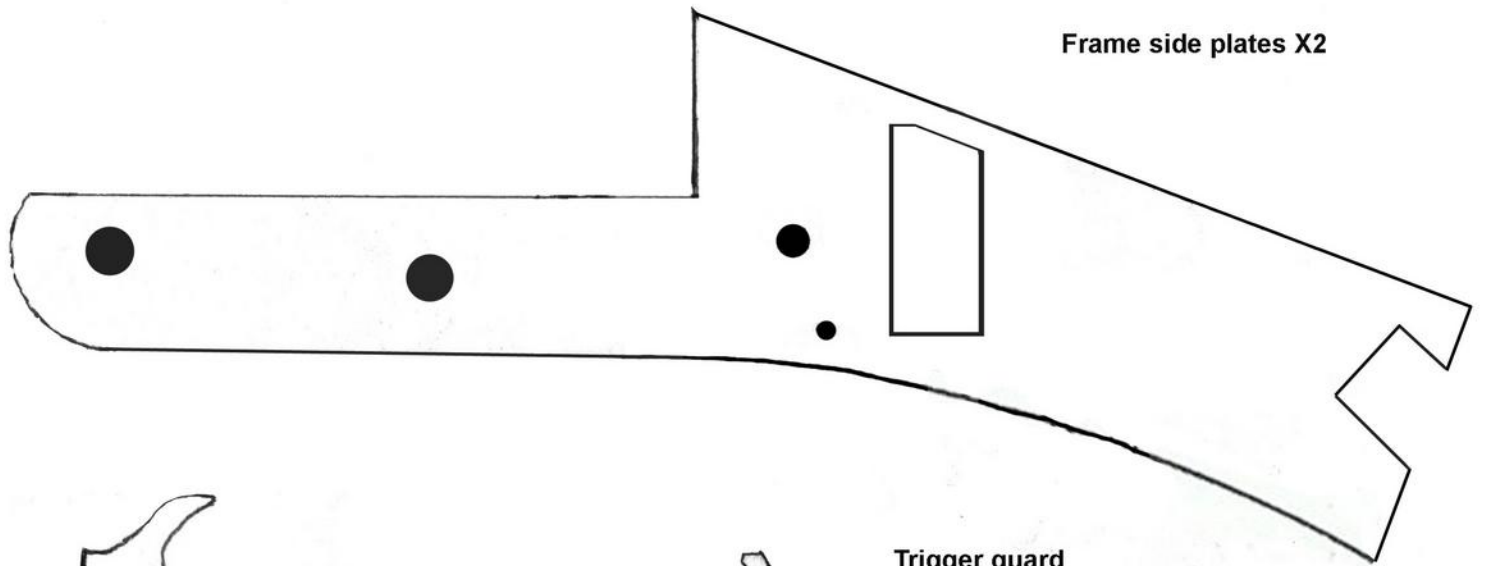

Compression spring
3/4" long, 10mm wide, 2mm thick wire

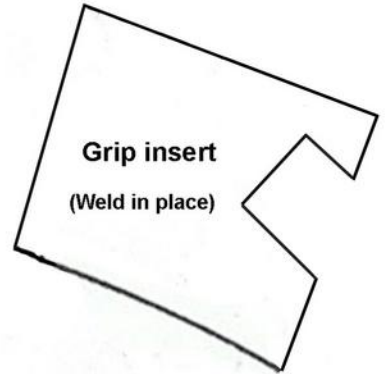

Secure with appropriate dia 1" long pins or nuts & bolts

2 inches

Print on 8.5x11 US letter paper

Frame side plates : 1/4" (4mm to 6mm thick) mild steel plate
Hammer, trigger, grip insert and barrel lug : 1/4" (6mm) thick mild steel plate
Trigger guard : 2mm thick, 8mm wide, 4.5" long mild steel strip

Breech assembly

1" dia mild steel round bar, 15mm long

Drill with a 2mm bit through front. Bore out rear with a 4.2mm, 12mm deep.

Drill a hole from above until entering firing pin channel. Add threads with a 4mm hand tap.

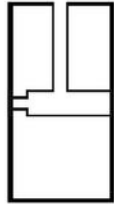

Side

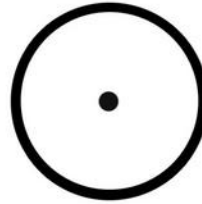

Front

Firing pin

(4mm dia silver steel bar)

Spin in a drill press and use a hand file to turn down front portion in dia.

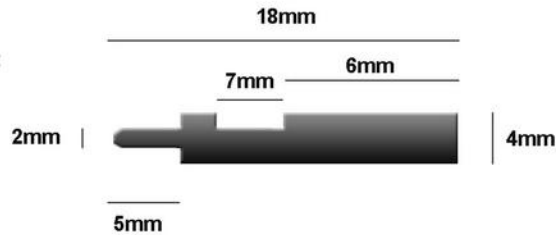

Assembled:

A small dia compression spring taken from a pen is modified by shortening it to 3 or 4 coils and is positioned in front of the firing pin.

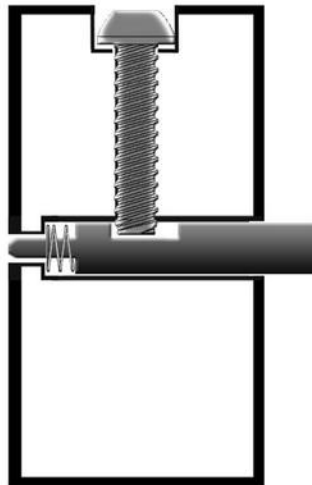

Thread a 10mm long m4 bolt down until firing pin is made freely captive via its slot. Apply loctite to bolt to retain in position.

Insert a piece of 1/4" (6mm) plate between side plates to ensure correct inner dimensions remain while welding frame components together.

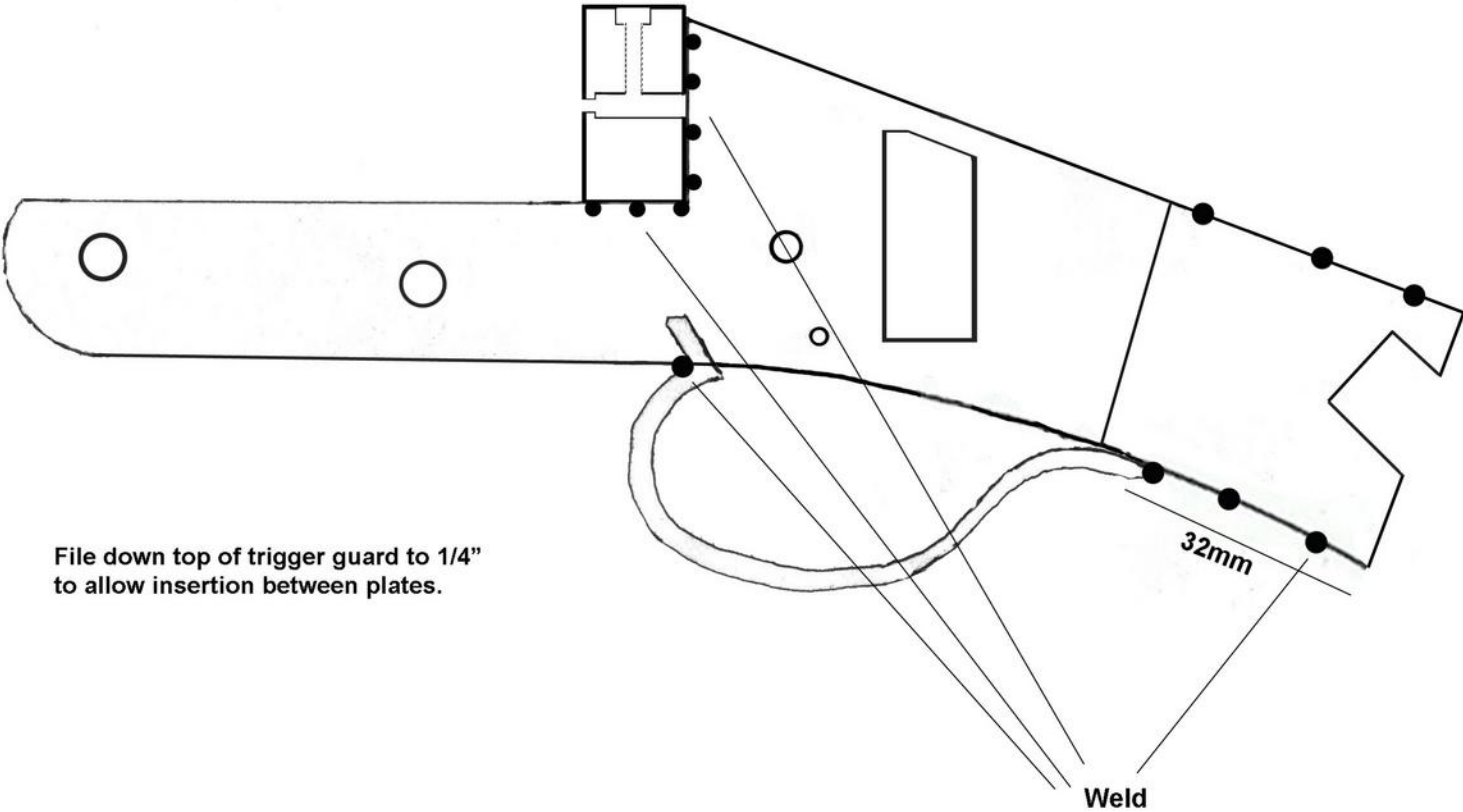

File down top of trigger guard to 1/4" to allow insertion between plates.

2 inches

Print on 8.5x11 US letter paper

Barrel

1" outside diameter, 3/4" inner diameter seamless steel tube, 20" long. Can be sleeved with a section of 1" inner diameter steel tube for maximum thickness.

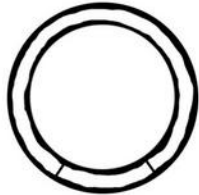

File shallow extraction cut into lower wall

Bevel inner wall using a dremel to accommodate rim

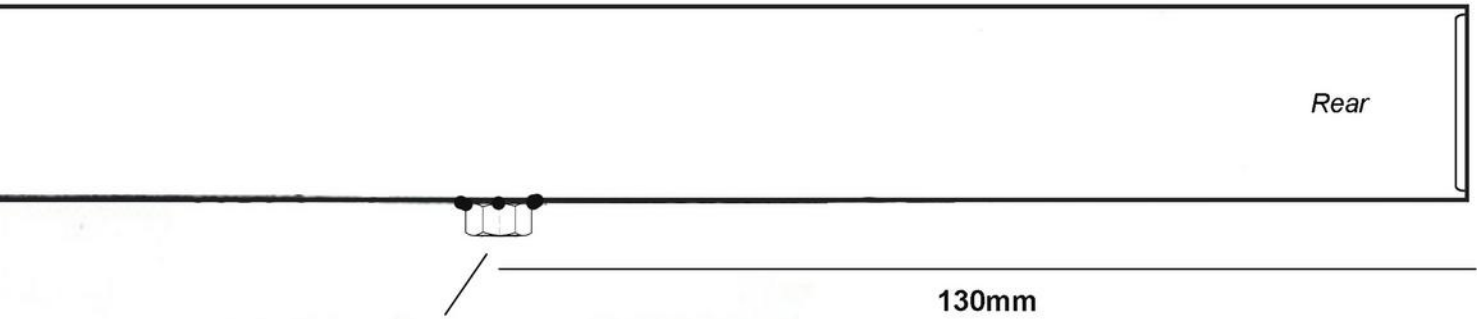

Weld or braze an M6 nut to bottom of barrel

130mm

Drill a 2.5mm hole and tap for an M3 button head bolt to serve as a sight bead

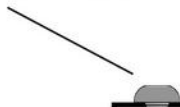

Front

Barrel lug and latch

Weld lug onto barrel before drilling through corresponding holes in frame to ensure tight fit and alignment.

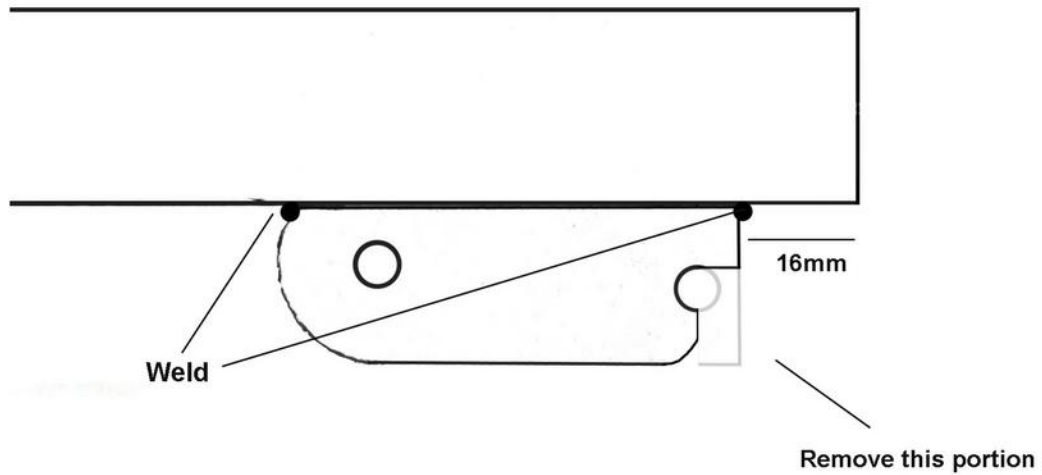

Latch

Tap a modified 1" long m6 bolt into a length of 3mm steel plate. Weld at front. Apply thread locker to ensure firmness in both closed and open position.

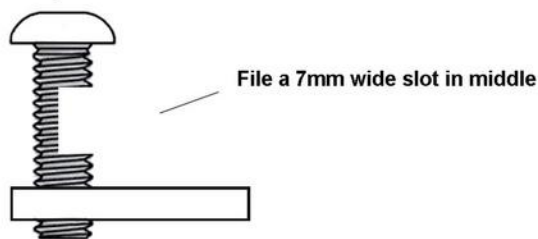
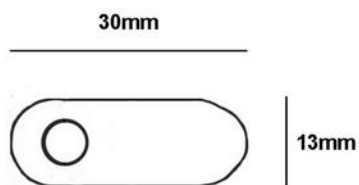

2 inches

Forearm

1" or 1.5" thick hardwood
7.5" long

Front profile:



Drill a hole 130mm from front
to accept an M6 bolt

2 inches

Print on 8.5x11 US letter paper

Stock

1.5" thick hardwood

14.5" long



2 inches

Print on 8.5x11 US letter paper

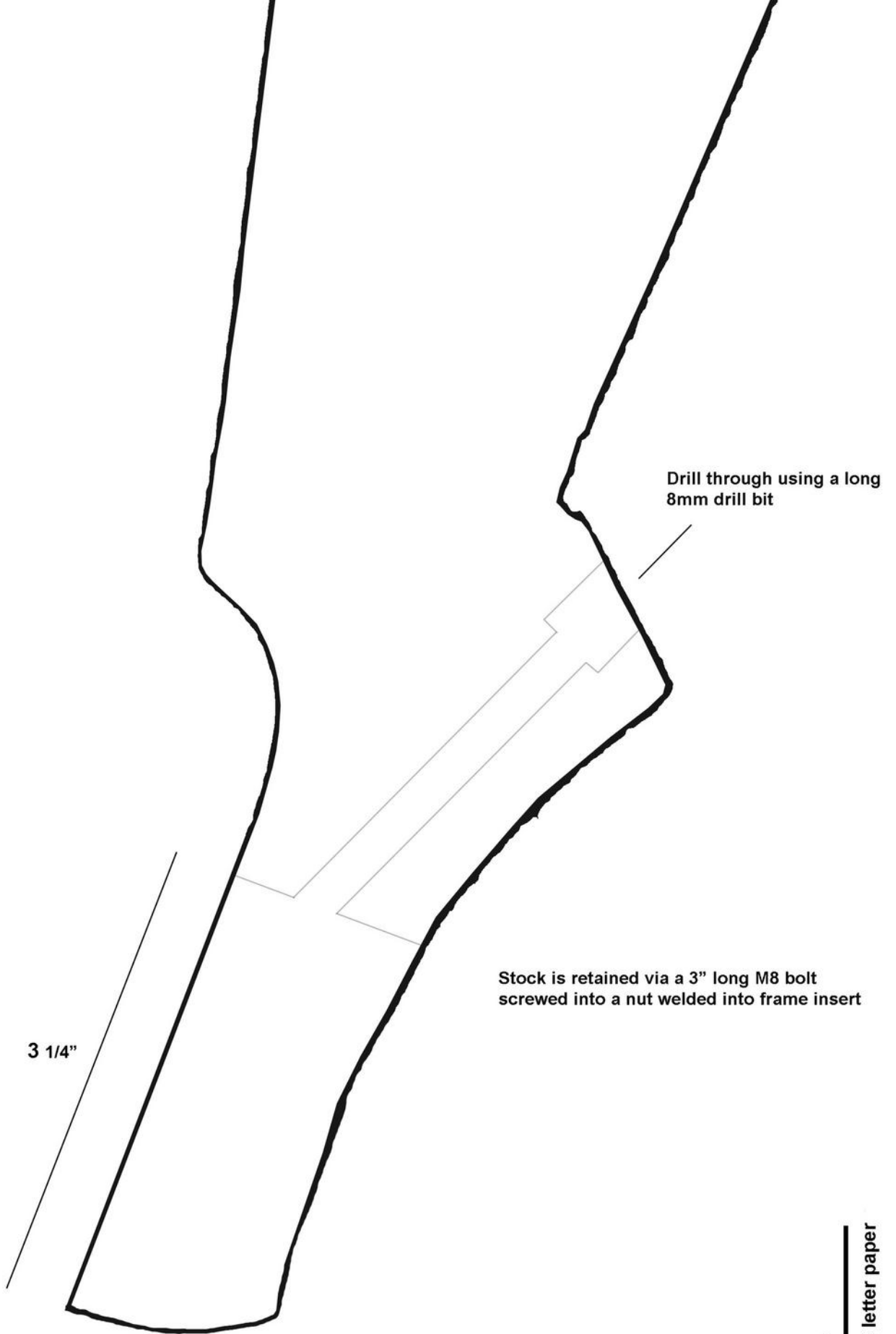

Carve out a 14mm wide, 3 1/4" deep slot through middle to accommodate rear of frame

2 inches

Print on 8.5x11 US letter paper

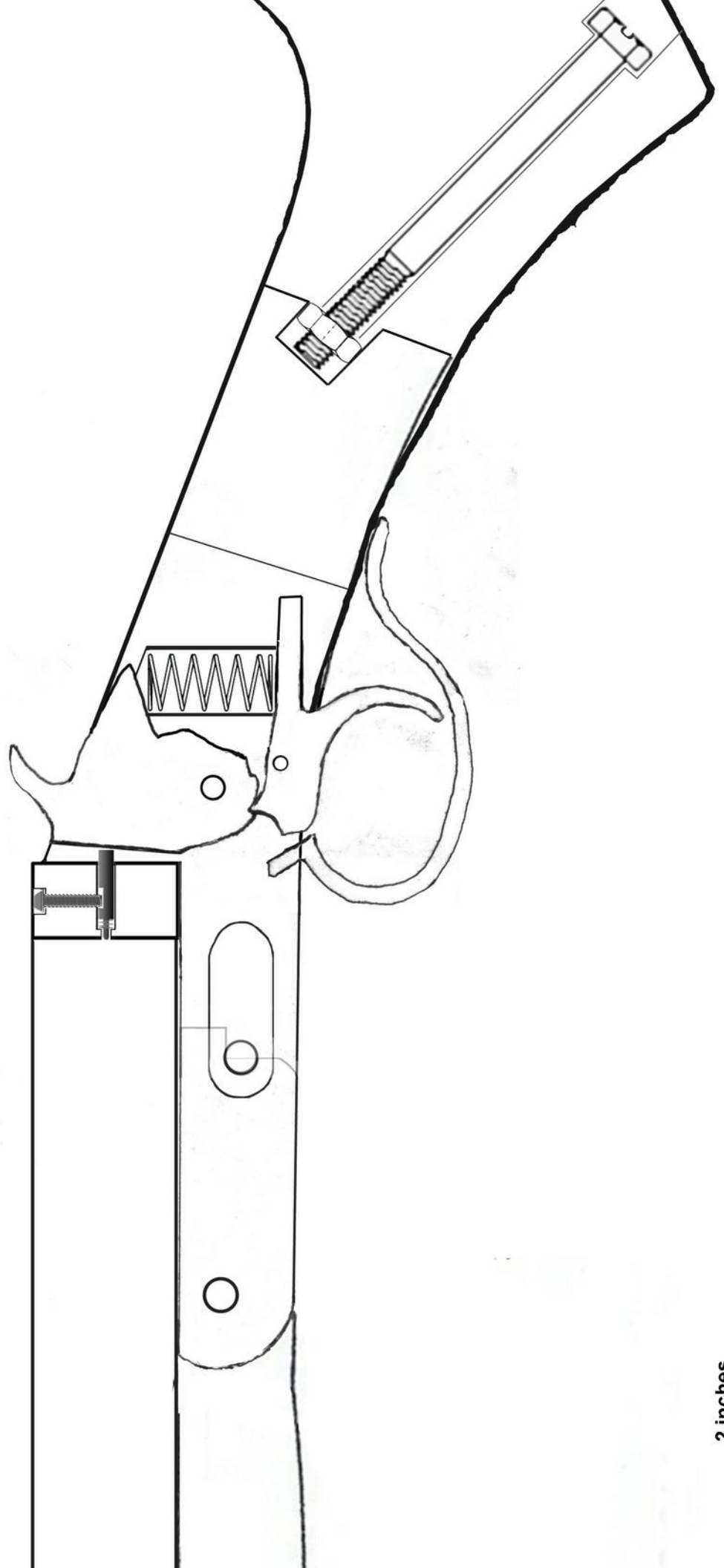

2 inches

Print on 8.5x11 US letter paper

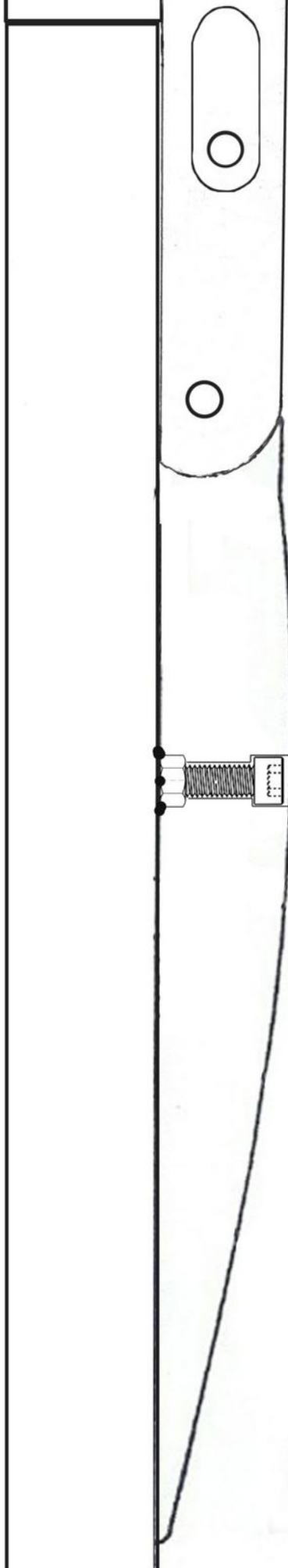

2 inches

Print on 8.5x11 US letter paper

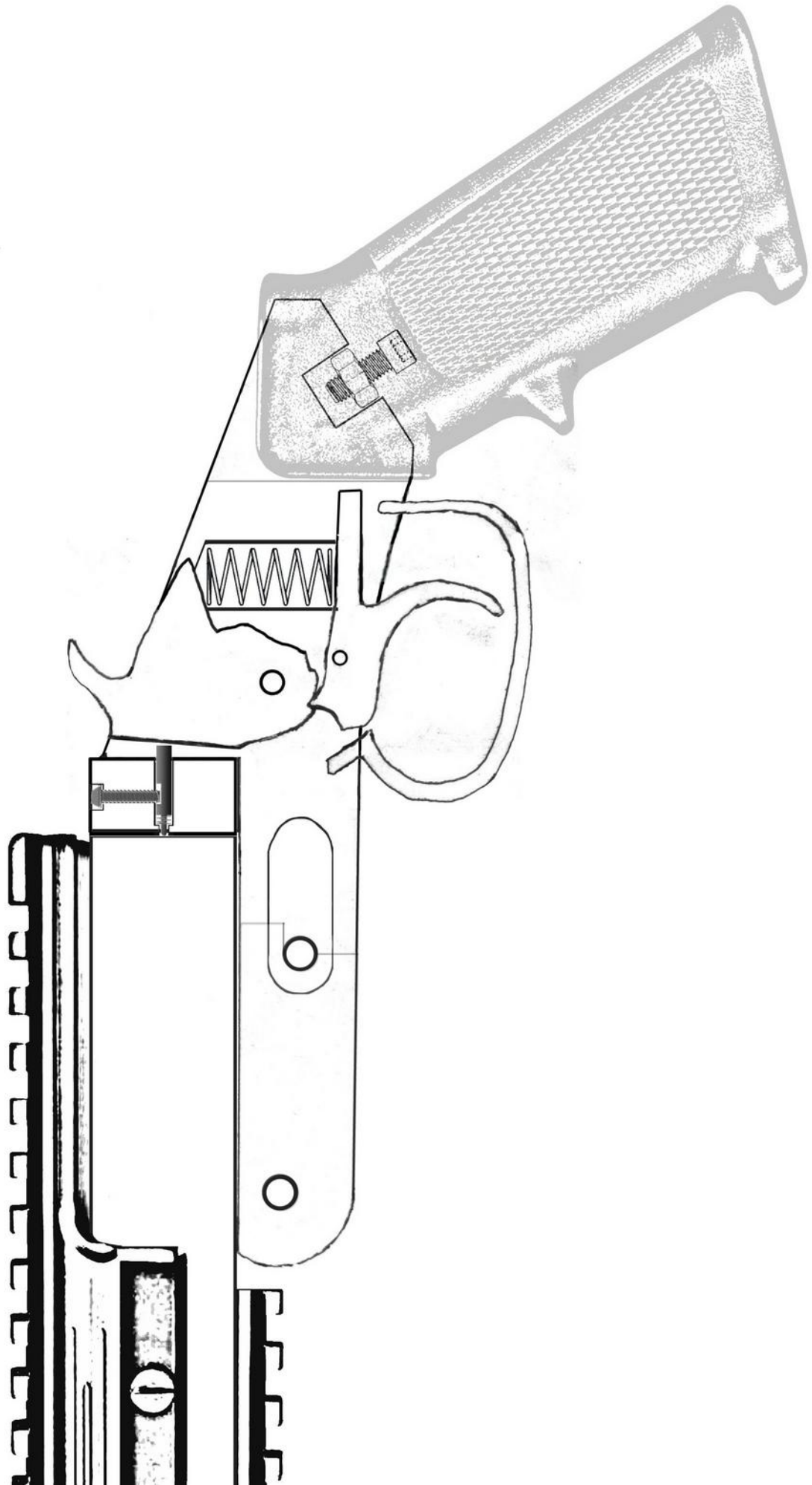

2 inches

Print on 8.5x11 US letter paper

Frame modifications to accept an M16 / AR15 pistol grip

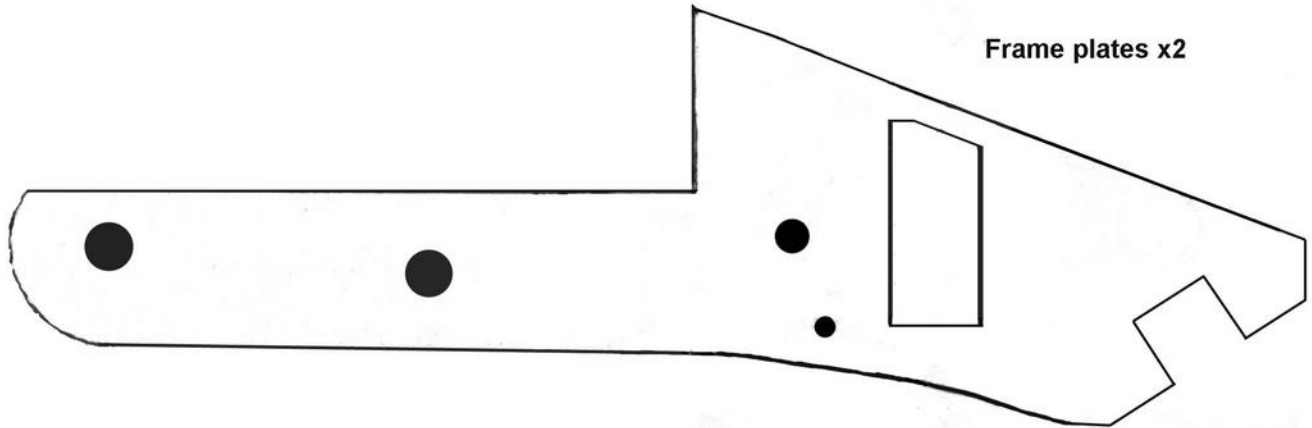

Spring channel cover x2

- Secure in place with two 24mm long pins

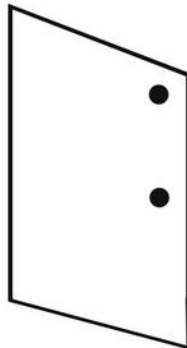

Grip insert

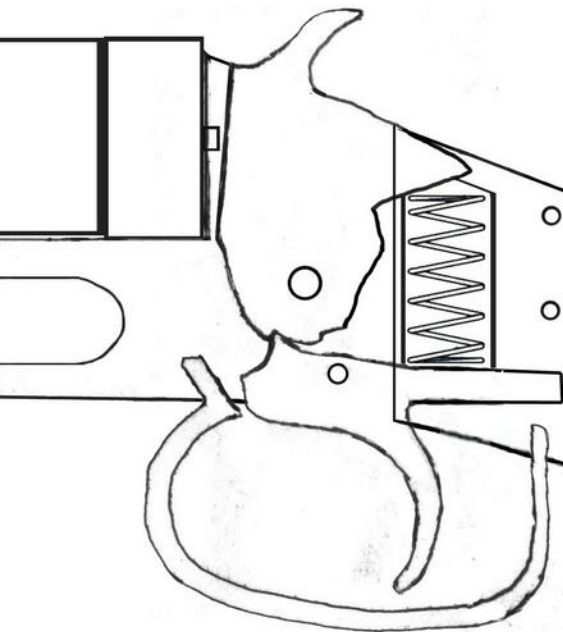
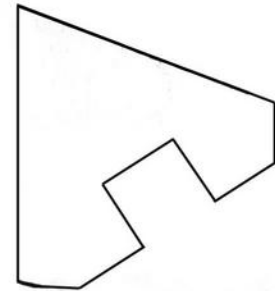

Reduce thickness of rear portion to 9.5mm using an angle grinder

Weld an M6 nut in place and secure grip with an M6 bolt

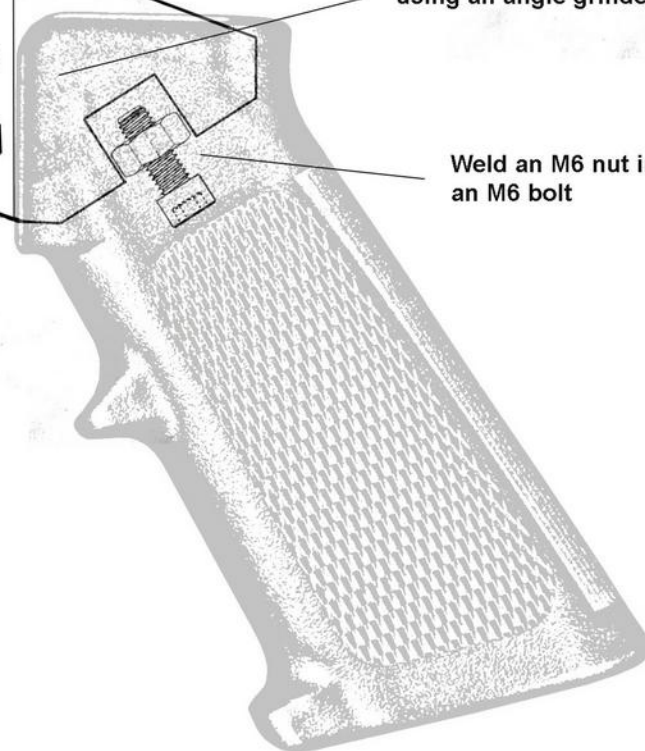

2 inches

Print on 8.5x11 US letter paper



Non-firing dummy replica mocked up in 'inner city gun buyback' configuration.